

Dismantling Joints PN 10

No.	Part Destination	Materials
1	Pipe	Ductile Iron
2	Body	Ductile Iron
3	Retainer	Ductile Iron
4	Ring	Rubber
5	Stud	SS304

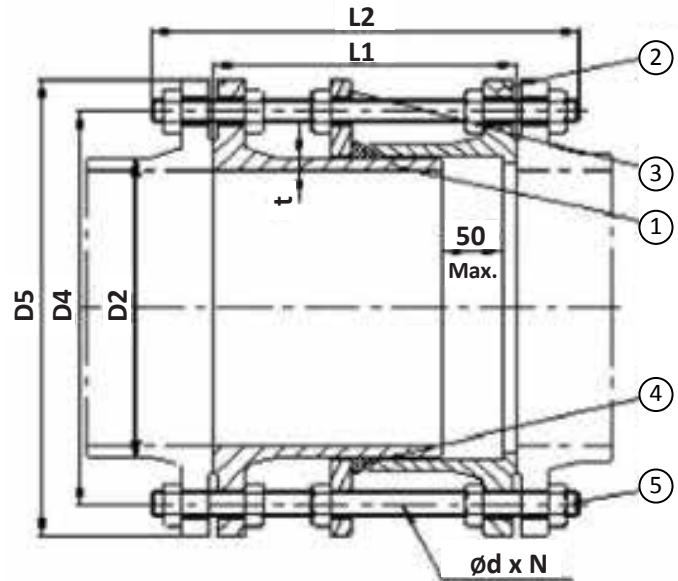

*Flange in accordance with ISO2531 PN10.

**Nominal Pressure: 16 bar, Test Pressure: 25 bar

Size		Main Dimension							
Inch	DN	D2	D4	D5	L1	L2	d(\varnothing)	N	t
3"	80	98	160	200	200	310	M16	8	7.0
4"	100	118	180	220	200	310	M16	8	7.2
5"	125	144	210	250	200	310	M16	8	7.5
6"	150	170	240	285	200	320	M20	8	7.8
8"	200	222	295	340	220	340	M20	8	8.4
10"	250	274	350	400	230	370	M20	12	9.0
12"	300	326	400	455	250	410	M20	12	9.6
14"	350	378	460	505	260	410	M20	16	10.2
16"	400	429	515	565	270	430	M24	16	10.8
18"	450	480	565	615	270	430	M24	16	11.4
20"	500	532	620	670	280	440	M24	20	12.0
24"	600	635	725	780	300	480	M27	20	13.2
28"	700	738	840	895	300	480	M27	24	14.4
32"	800	842	950	1015	320	520	M30	24	15.6
36"	900	945	1050	1115	320	520	M30	28	16.8
40"	1000	1048	1160	1230	340	560	M33	28	18.0
44"	1100	1152	1270	1340	340	560	M33	32	19.2
48"	1200	1255	1380	1455	360	600	M36	32	20.4
56"	1400	1462	1590	1675	380	630	M39	36	22.8
60"	1500	1565	1700	1785	400	665	M39	36	23.0
64"	1600	1668	1820	1915	400	700	M45	40	25.2
72"	1800	1875	2020	2115	420	730	M45	44	27.6
80"	2000	2082	2230	2325	440	730	M45	48	30.0
88"	2200	2288	2440	2550	450	750	M52	52	32.4
96"	2400	2495	2650	2760	460	770	M52	56	34.8
104"	2600	2702	2850	2965	500	800	M52	60	37.2