



SCOTCH & YOKE PNEUMATIC ACTUATOR VT-DFA SERIES



VAHN-TECH International Inc., headquartered in Toronto, Canada is a unique company within the Flow Control Industry.

- ✳ 'vt' brand = high quality certified products (API, NSF, CSA, WRAS etc.)
- ✳ Valves, Actuators and Accessories – all 'vt' branded
- ✳ Width and Depth of Product Offerings
- ✳ Flexibility to customize products to customer needs
- ✳ Specialized user-friendly products including large sizes
- ✳ Quick Response
- ✳ Reduced Delivery times
- ✳ Efficient after sales service
- ✳ Competitive Pricing

VAHN-TECH International Inc. is a customer focused organization based on “Value-add” and “Quality Service” principles. Achieving long term partnership with our customers and being their supplier of choice is our prime mission.

We develop, manufacture and market VAHN-TECH (vt) branded Valves, Actuators, Automatic Control Valves and Accessories for variety of Industrial Applications. Our product range includes:



We can supply all types of valves with following materials of construction like:

Ductile Iron, Cast Iron, Carbon Steel, Stainless Steel – SS304, SS304L, SS316, SS316L, Duplex Stainless Steel, Super Duplex, Alloy, Monel and Inconel with variety of seating and stem configurations.



Features

- ✦ VT-DFA series Scotch and Yoke Pneumatic Actuators are heavy-duty actuators for operating large diameter ball valves, butterfly valves, plug valves and other 90° rotating mechanisms.
- ✦ The piston rod and guide block connection, superior surface finish and the self-lubricating bearings maximize the input energy transfer directly to the valve stem and ensure reliable operation over the service life of the actuator. Efficiency is further enhanced by the tension-loaded spring, minimizing radial loads on the piston rod.
- ✦ VT-DFA series actuators incorporate three stages of internal and external coatings to resist severe weather, chemical and petroleum environment. The inner surface of cylinder is coated by PTFE, that provides enhanced corrosion resistance and is self-lubricating.
- ✦ VT-DFA series actuators can be supplied with the complete line of controls and monitoring accessories, including hand wheel, hydraulic manual override, limit switches, solenoid valves, positioners and other control accessories.
- ✦ The modular design of the Scotch & Yoke makes it suitable for all type of application. It is extremely convenient and easy to handle during storage, installation and maintenance operation. Modules are removable, serviceable and interchangeable when mounted on the valve.
- ✦ To ensure the safety of personnel during installation and maintenance, the spring module has been designed so that it only be removed from the power module with the spring in the fully extended position. This prevents accidental release of the spring force, protecting personnel from injury and the actuator from accidental damage.

Specifications:

- ✦ Torque Range:

Double Acting Actuator:	Min 977N.m / Max 24,000 N.m
Spring Return Actuator:	Min 854N.m / Max 29,000 N.m

* For additional options and higher torque, please contact us.

- ✦ The valve mounting interface meets ISO 5211 standard dimensional requirements and all connecting interfaces conform to NAMUR requirements.
- ✦ VT-DFA Series possesses two independent travel adjustment bolts, allowing for $\pm 10^\circ$ adjustment of the valve opening position.

- ✦ Working Temperature:

Standard Temperature:	-20°C~+80°C
Low Temperature:	-40°C~+80°C
High Temperature:	-20°C~+150°C

- ✦ VT-DFA Series actuators comply with IP65 protection class.

Design & Construction

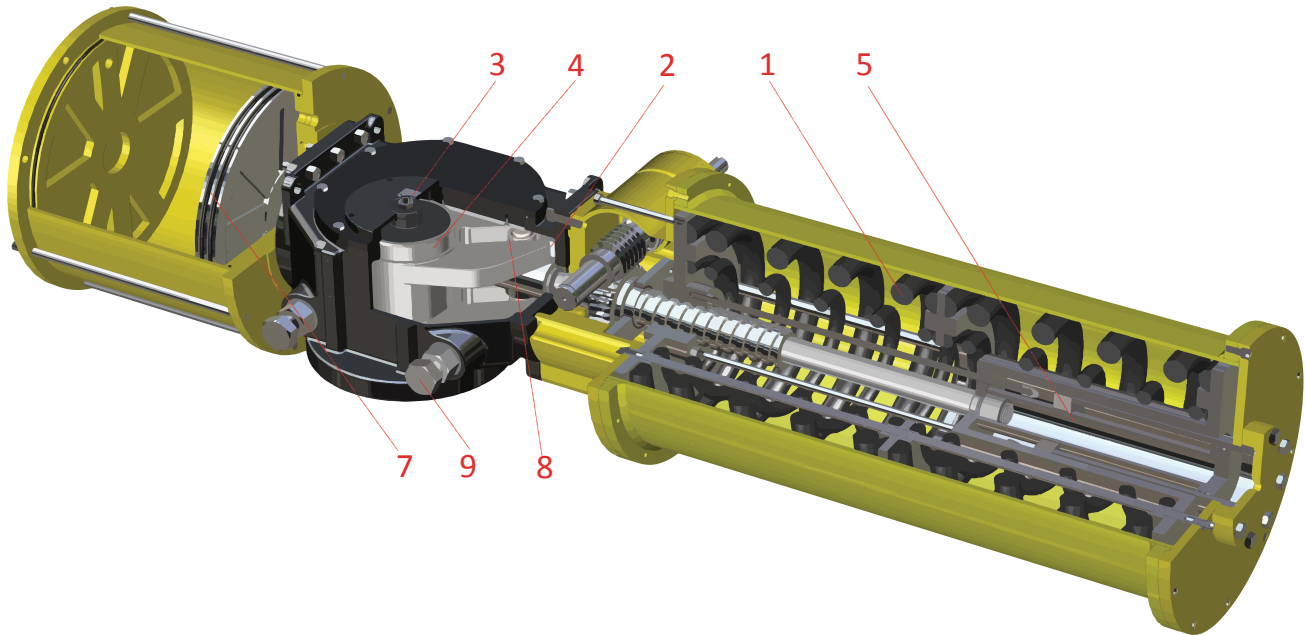

1. Pre-compressed spring unit

Specially designed spring module with adjustable output torque and replaceable spring to fit different type of valve torque. Pre-compressed spring unit is easy to exchange and ensure safe operation.

2. Reduced Wear

The piston rod connects with the guide block to compensate for side load deflection, reducing wear on rod, bearings and seals. Advanced surface treatment is used on piston rod and guide block to provide superior wear resistance and extends the service life.

3. Standardized Mounting

The NAMUR mounting configuration allows standardization of mounting hardware for a wide range of shaft driven accessories.

4. Replaceable Bearings

Replaceable Bearings protect sliding and rotating components with suitability for either dry or lubricated working conditions.

5. Hydraulic Overrides for Spring Module

Optional Hydraulic Override for Spring Return actuator is internal to the cylinder module and does not increase the actuator length.

6. Easy Lifting

Actuators are equipped with lifting eyes for safe handling during shipping, installation and maintenance.

7. PTFE Guide Ring

PTFE Guide Ring prevents metal to metal contact with the cylinder bore, ensuring the cylinder is not damaged by the piston while helping reducing friction.

8. Roller

Rollers are used to reduce the friction between the yoke arm and pin, minimizing the wear of yoke arm and pin.

9. Travel Adjustment

Bi-Directional Travel Stops allow for 80° to 100° total travel adjustment.

Modular Design

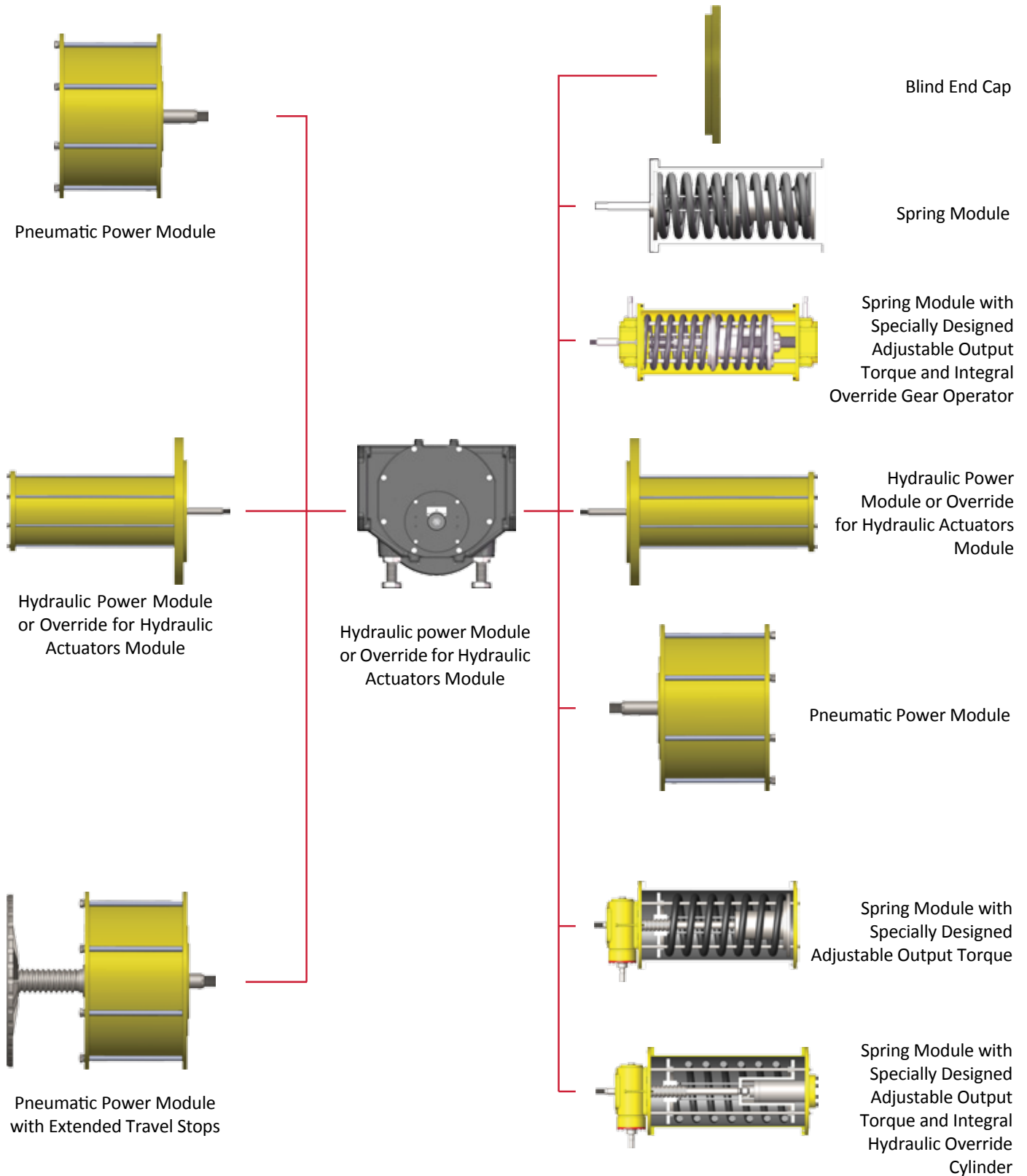

Torque Characteristics

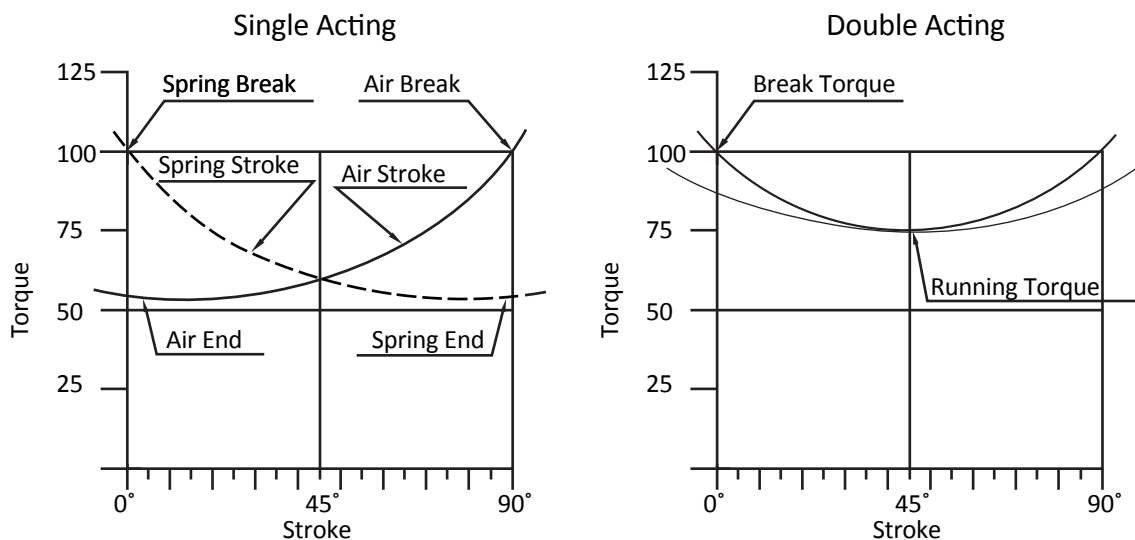

Torque Characteristics of Three Different Types of 90° Travel Valves

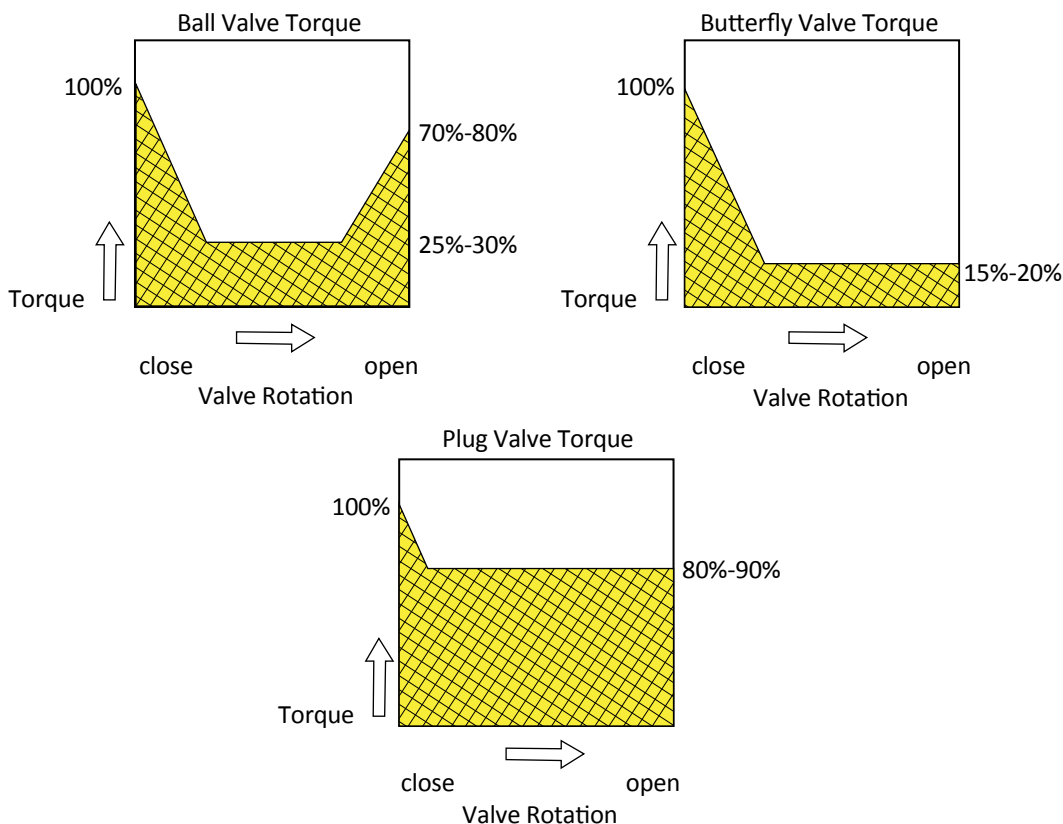

Assembly Drawing

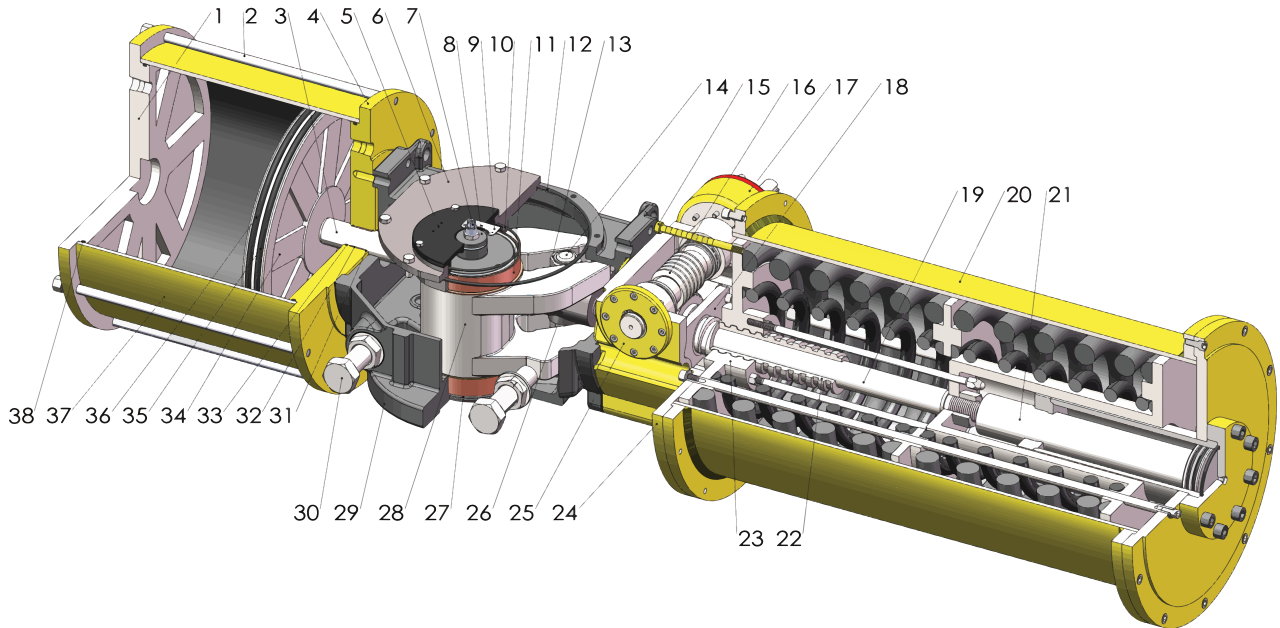

No.	Description	Material
1	Cylinder End Cap	QT500-7
2	Stud	C45
3	Piston Rod	Alloy Steel
4	Cylinder End Cap	QT500-7
5	Up Cover	HT200
6	Cover	QT500-7
7	Indicator Cap	C45
8	Small Cover	HT200
9	Indicator Board	Al
10	O-Ring	NBR
11	Bearing	H62
12	O-Ring	NBR
13	Roller	GCr15
14	Pin	GCr15
15	Torque Indicator Pin	45
16	Worm	45
17	Energy Saving Unit	/
18	Supporting Seat	45
19	Tension Rod	45

No.	Description	Material
20	Spring Module	/
21	Hydraulic Module	/
22	Lead Screw	C45
23	Spring Seat	C45
24	End Cap	Carbon Steel
25	End Cap	C45
26	Guide Block	QT500-7
27	O-Ring	NBR
28	Yoke	Carbon Steel
29	Body	Carbon Steel
30	Adjust Bolt	C45+Ni
31	Circlip	65Mn
32	Bearing	H62
33	O-Ring	NBR
34	Piston	Carbon Steel
35	O-Ring	NBR
36	Guide Ring	PTFE
37	Cylinder	C20
38	O-Ring	NBR

Torque Sheet (N.m)

Double Acting

Model	Max Torque of Drive Module	Air Pressure									
		3 Bar		4 Bar		5 Bar		6 Bar		7 Bar	
		Break	Run	Break	Run	Break	Run	Break	Run	Break	Run
VT-DFA16-250	4000	1642	977	2190	1302	2738	1628	3286	1945	3834	2279
VT-DFA16-300		2335	1388	3114	1852	3893	2315	-	-	-	-
VT-DFA16-350		3150	1873	4200	2497	-	-	-	-	-	-
VT-DFA25-350	8000	3976	2349	5301	3133	6627	3917	7953	4700	-	-
VT-DFA25-400		5123	3027	6831	4037	8539	5047	-	-	-	-
VT-DFA25-450		6415	3791	8555	5055	-	-	-	-	-	-
VT-DFA30-450	16000	7863	4651	10484	6203	13104	7753	15726	9304	-	-
VT-DFA30-500		9624	5694	12833	7593	16041	9491	-	-	-	-
VT-DFA30-550		11565	6842	15420	9123	-	-	-	-	-	-
VT-DFA35-550	32000	15002	8904	19651	11752	25002	14839	29477	17630	35004	20775
VT-DFA35-600		17749	10535	23250	13906	29581	17557	34875	20859	-	-
VT-DFA35-700		23936	14206	31355	18753	-	-	-	-	-	-

Spring Return Acting Torques (N.m) - Air Supply Pressure 4 bar

Model	Max Torque of Drive Module	Air Start (BTO)	Air End (ETO)	Spring Break (BTC)	Spring End (ETC)
VT-DFA16-250	4000	1281	854	1347	898
VT-DFA16-300		1822	1214	1915	1277
VT-DFA16-350		2457	1638	2583	1722
VT-DFA25-350	8000	3101	2067	3260	2173
VT-DFA25-400		3996	2664	4201	2801
VT-DFA25-450		5005	3336	5261	3508
VT-DFA30-450	16000	6133	4089	6448	4298
VT-DFA30-500		7507	5005	7892	5262
VT-DFA30-550		9021	6014	9483	6322
VT-DFA35-550	32000	11496	7664	12085	8057
VT-DFA35-600		13601	9068	14299	9533
VT-DFA35-700		18343	12228	19283	12856

Torque Sheet (N.m)

Spring Return Acting Torques (N.m) - Air Supply Pressure 5 bar

Model	Max Torque of Drive Module	Air Start (BTO)	Air End (ETO)	Spring Break (BTC)	Spring End (ETC)
VT-DFA16-250	4000	1602	1068	1684	1123
VT-DFA16-300		2277	1518	2394	1596
VT-DFA16-350		3071	2048	3229	2153
VT-DFA25-350	8000	3877	2585	4076	2717
VT-DFA25-400		4995	3330	5251	3501
VT-DFA25-450		6255	4170	6576	4384
VT-DFA30-450	16000	7666	5111	8059	5373
VT-DFA30-500		9384	6256	9865	6577
VT-DFA30-550		11276	7517	11854	7903
VT-DFA35-550	32000	14626	9751	15376	10251
VT-DFA35-600		17305	11537	18192	12128
VT-DFA35-700		23338	15559	24535	16357

Spring Return Acting Torques (N.m) - Air Supply Pressure 6 bar

Model	Max Torque of Drive Module	Air Start (BTO)	Air End (ETO)	Spring Break (BTC)	Spring End (ETC)
VT-DFA16-250	4000	1922	1282	2021	1347
VT-DFA16-300		2733	1822	2873	1916
VT-DFA16-350		3686	2457	3875	2583
VT-DFA25-350	8000	4653	3102	4891	3261
VT-DFA25-400		5994	3996	6302	4201
VT-DFA25-450		7507	5004	7892	5261
VT-DFA30-450	16000	9200	6133	9671	6448
VT-DFA30-500		11261	7508	11839	7893
VT-DFA30-550		13531	9021	14225	9483
VT-DFA35-550	32000	17244	11496	18128	12086
VT-DFA35-600		20402	13601	21448	14229
VT-DFA35-700		27514	18343	28925	19284

BTO = Break To Open Torque (Air Start)
 ETO = End to Open Torque (Air End)
 BTC = Break To Close Torque (Spring Start)
 ETC = End To Close Torque (Spring End)

Dimension (mm)

Model	D	E	E1	E2	H	L1	L2	L	M	D1	D2	n	M1	B	T	Air Connection
VT-DFA16-250	310	75	105	230	107	507	682	1634	M6	80	165	4	M20	22	85.4	RC 1/2
VT-DFA16-300	370	75	105	260	107	507	682	1634	M6	80	165	4	M20	22	85.4	RC 1/2
VT-DFA16-350	420	75	105	285	107	507	682	1634	M6	80	165	4	M20	22	85.4	RC 1/2
VT-DFA25-350	440	90	150	310	103	570	779	1862	M6	100	254	8	M16	28	106.4	RC 1/2
VT-DFA25-400	490	90	150	355	103	570	779	1862	M6	100	254	8	M16	28	106.4	RC 3/4
VT-DFA25-450	540	90	150	360	103	570	779	1862	M6	100	254	8	M16	28	106.4	RC 3/4
VT-DFA30-450	540	110	176	380	137	700	947	1923	M8	120	298	8	M20	32	127.4	RC 3/4
VT-DFA30-500	590	110	176	405	137	700	947	1923	M8	120	298	8	M20	32	127.4	RC 3/4
VT-DFA30-550	650	100	176	435	137	700	947	1923	M8	120	298	8	M20	32	127.4	RC 3/4
VT-DFA35-550	650	143	208	468	155	895	1205	2543	M8	160	356	8	M30	40	169.4	RC 3/4
VT-DFA35-600	710	143	208	498	155	895	1205	2543	M8	160	356	8	M30	40	169.4	RC 1
VT-DFA35-700	820	143	208	553	155	895	1205	2543	M8	160	356	8	M30	40	169.4	RC 1

Spring Return VT-DFA16/VT-DFA25

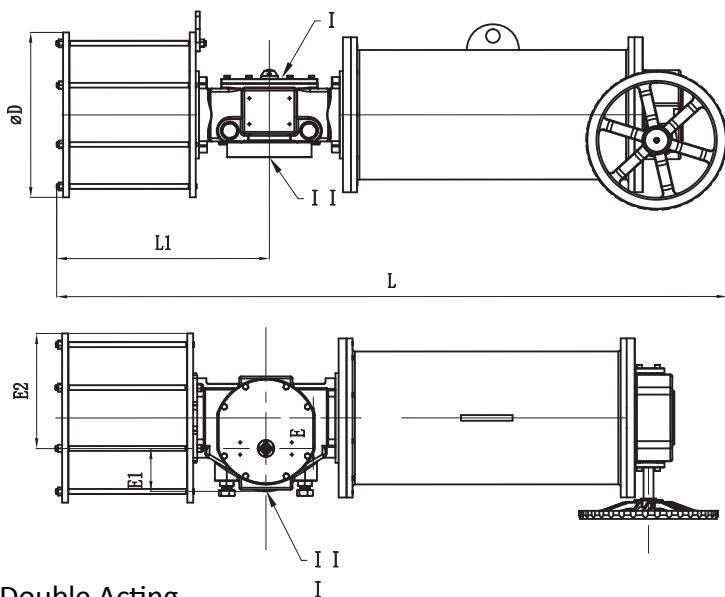

Spring Return VT-DFA30/VT-DFA35

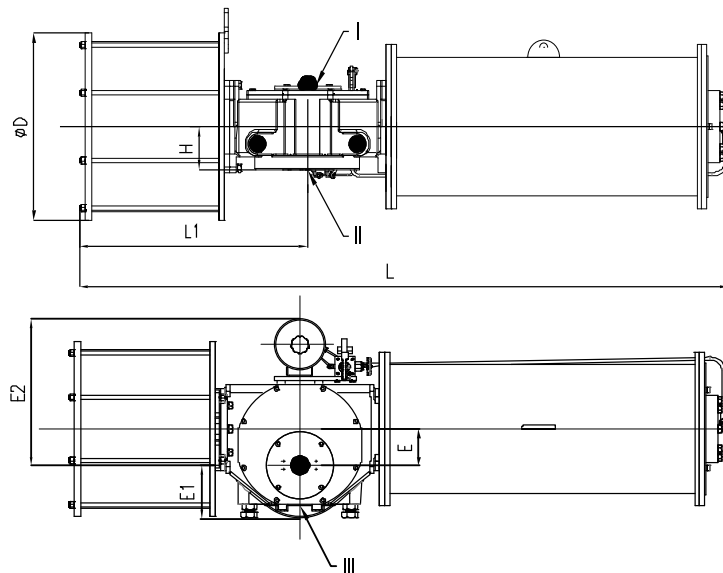

Double Acting

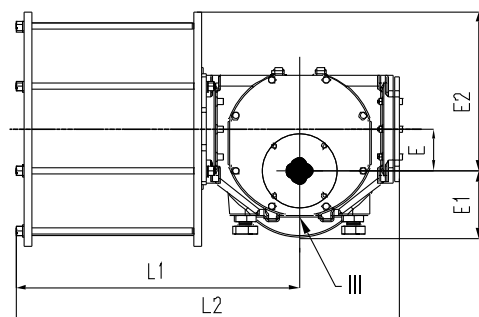

Detail I

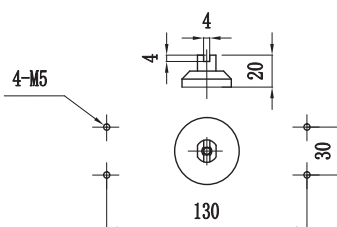

Detail II

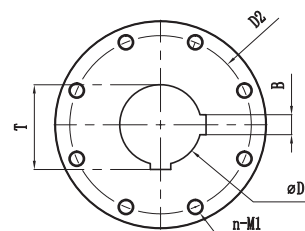

Detail III

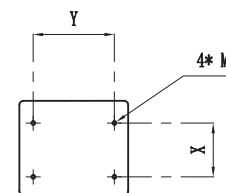

ACTUATOR SELECTION

VT-DFAXX - XXX - S - 4/5 - L - HY - FC

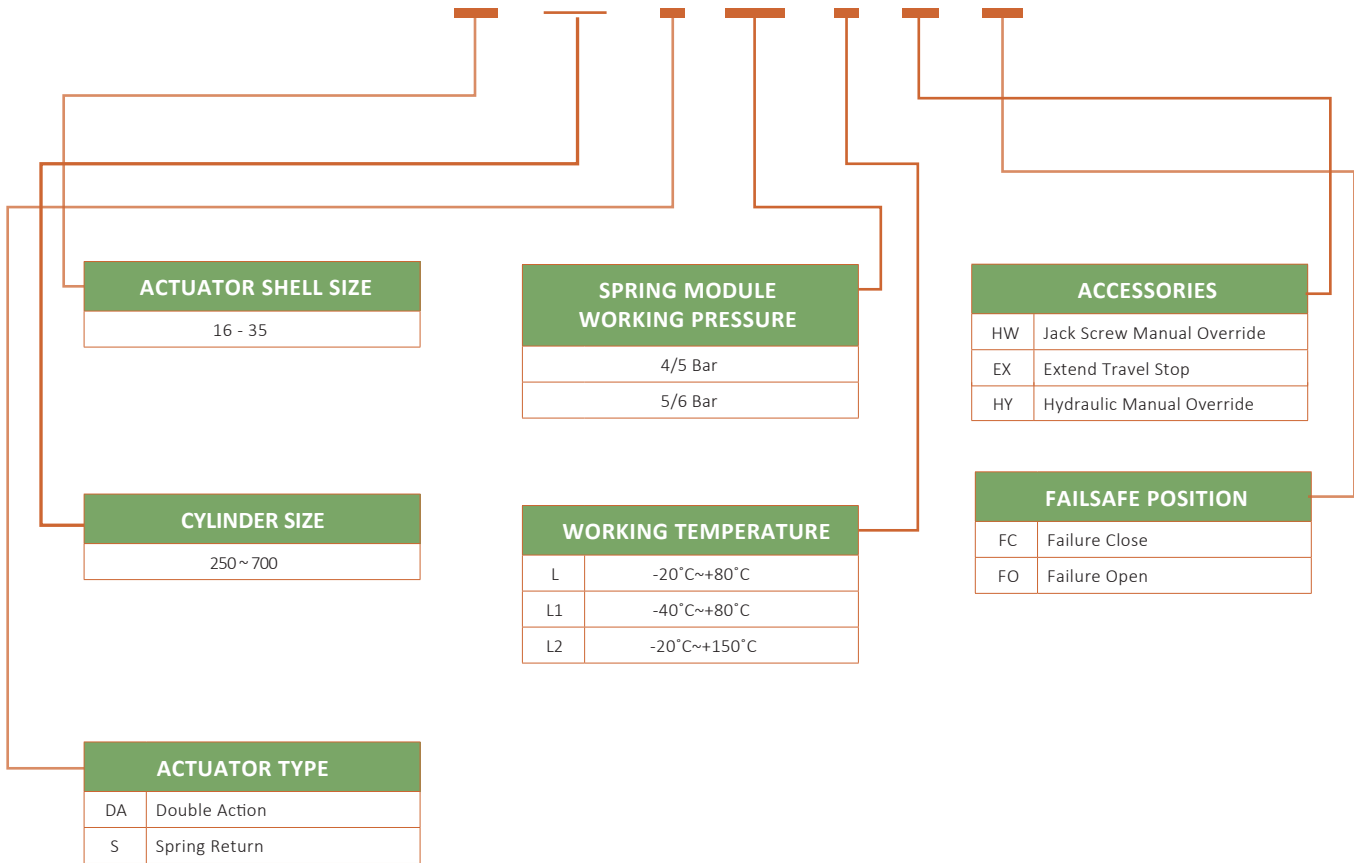



VAHN-TECH International Inc.

10-755 Queensway East, Mississauga, Ontario L4Y 4C5, Canada
Tel.: +1 416 342 0001 E-mail: info@vahn-tech.com

www.vahn-tech.com