



KNIFE GATE VALVES





VAHN-TECH International Inc., headquartered in Toronto, Canada is a unique company within the Flow Control Industry.

- ✳ 'vt' brand = high quality certified products (API, NSF, CSA, WRAS etc.)
- ✳ Valves, Actuators and Accessories – all 'vt' branded
- ✳ Width and Depth of Product Offerings
- ✳ Flexibility to customize products to customer needs
- ✳ Specialized user-friendly products including large sizes
- ✳ Quick Response
- ✳ Reduced Delivery times
- ✳ Efficient after sales service
- ✳ Competitive Pricing

VAHN-TECH International Inc. is a customer focused organization based on “Value-add” and “Quality Service” principles. Achieving long term partnership with our customers and being their supplier of choice is our prime mission.

We develop, manufacture and market VAHN-TECH (vt) branded Valves, Actuators, Automatic Control Valves and Accessories for variety of Industrial Applications. Our product range includes:



Oil and Gas



Water and Sewage,
Desalination



Chemicals



Paper and Pulp



Irrigation



Power Plants



Various
Industrial Applications

We can supply all types of valves with following materials of construction like:

Ductile Iron, Cast Iron, Carbon Steel, Stainless Steel – SS304, SS304L, SS316, SS316L, Duplex Stainless Steel, Super Duplex, Alloy, Monel and Inconel with variety of seating and stem configurations.



DB Series - Funnel Type

Vahn-Tech DB Series funnel knife gate valve is used in service as a pneumatic residue discharge valve in pulp making, paper making and sewage treatment. This type of valve is well suited for high consistency media containing solids, fiber or residue, serving as a residue discharge valve on stock cleaners, gravity separators or pressurized screens. The “funnel” at the bottom of the collects waste discharged from the valve body during the closing stroke. This greatly reduces the wear between the body and gate, and prolongs the life cycle of the valve.

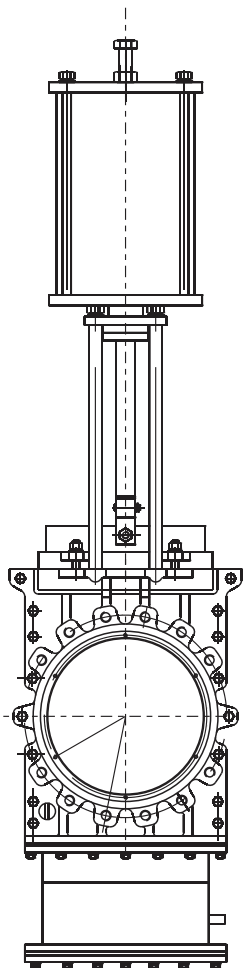

Features

1. A sight glass set at the bottom of the funnel allows for observation of the waste level in the funnel.
2. Valve is full port in the position with low flow resistance.
3. Two-piece body construction with no cavities eliminates product build-up.
4. Tight shutoff, reliable performance.
5. O-ring loaded removable seat is self-compensating with good abrasion resistance and long service life.
6. Available seat materials: Metal, PTFE or EPDM

Technical Specification

Specifications		
Size Range	4" - 16" / DN100 - DN400	
Flange Connection	ANSI Class 150	
Connection Type	Wafer Type	
Temperature Range	-20°C to 120°C (-4°F to 248°F)	
Applicable Medium	Pulp, Slurry, Sewage, Slag	
Nominal Pressure	10.3 bar (150 psi) for sizes up to 24" / 6.9 bar (100 psi) for sizes 28" and above	
Hydraulic Test	100% testing according to MSS SP-81 (respectively AWWA C520)	
	Shell	1.5*PN
	Packing	1.1*PN
	Seat	2.8 bar and maximum allowable differential pressure
DB Series are bi-directional up to 10 bar.		

DB Series - Funnel Type

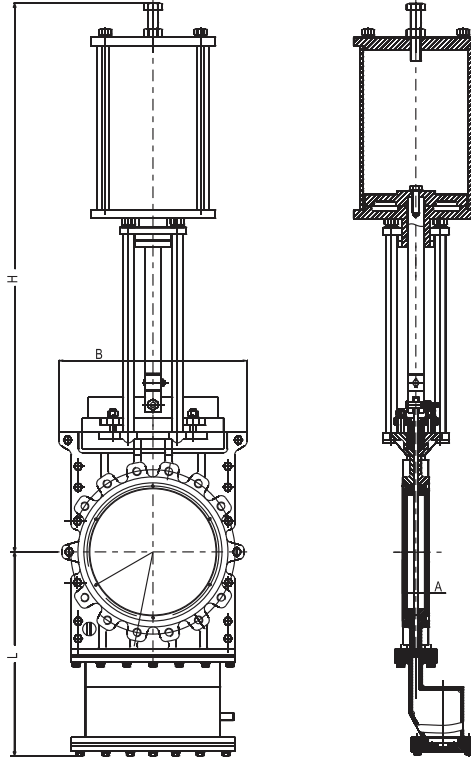

Dimensions

Size		Main Dimension (mm)			
NPS	DN	A	B	L	H
4"	100	51	220	310	650
5"	125	57	250	380	730
6"	150	57	270	400	820
8"	200	70	350	480	1040
10"	250	70	410	520	1230
12"	300	76	470	560	1390
14"	350	76	550	590	1590
16"	400	89	620	640	1750



VAHN-TECH International Inc.

10-755 Queensway East, Mississauga, Ontario L4Y 4C5, Canada

Tel.: +1 416 342 0001 E-mail: info@vahn-tech.com

www.vahn-tech.com