



## KNIFE GATE VALVES





**VAHN-TECH International Inc.**, headquartered in Toronto, Canada is a unique company within the Flow Control Industry.

- ✳ 'vt' brand = high quality certified products (API, NSF, CSA, WRAS etc.)
- ✳ Valves, Actuators and Accessories – all 'vt' branded
- ✳ Width and Depth of Product Offerings
- ✳ Flexibility to customize products to customer needs
- ✳ Specialized user-friendly products including large sizes
- ✳ Quick Response
- ✳ Reduced Delivery times
- ✳ Efficient after sales service
- ✳ Competitive Pricing

**VAHN-TECH International Inc.** is a customer focused organization based on “Value-add” and “Quality Service” principles. Achieving long term partnership with our customers and being their supplier of choice is our prime mission.

We develop, manufacture and market VAHN-TECH (vt) branded Valves, Actuators, Automatic Control Valves and Accessories for variety of Industrial Applications. Our product range includes:



Oil and Gas



Water and Sewage,  
Desalination



Chemicals



Paper and Pulp



Irrigation



Power Plants



Various  
Industrial Applications

We can supply all types of valves with following materials of construction like:

Ductile Iron, Cast Iron, Carbon Steel, Stainless Steel – SS304, SS304L, SS316, SS316L, Duplex Stainless Steel, Super Duplex, Alloy, Monel and Inconel with variety of seating and stem configurations.



## DF Series -Square Type

Vahn-Tech DF Series square knife gate valve is mainly used as pneumatic on/off valve for process control in pulp making slurry or sewage treatment. It is particularly suitable to serve as a residue discharger on equipment such as stock cleaners, gravity separators and hydra pulper in the paper making industry

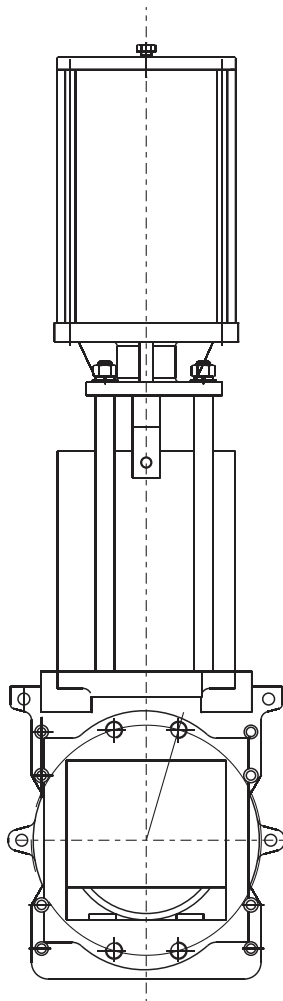

### Features

1. Valve is full port in the position with low flow resistance.
2. Two-piece body construction with no cavities eliminates product build-up.
3. Tight shutoff, reliable performance.
4. O-ring loaded removable seat is self-compensating with good abrasion resistance and long service life.
5. Available seat materials: Metal, PTFE or EPDM

### Technical Specification

Specifications		
Size Range	3" - 24" / DN80 - DN600	
Flange Connection	ANSI Class 150	
Connection Type	Wafer Type	
Temperature Range	-20°C to 120°C (-4°F to 248°F)	
Applicable Medium	Pulp, Slurry, Sewage, Slag	
Nominal Pressure	10.3 bar (150 psi) for sizes up to 24" / 6.9 bar (100 psi) for sizes 28" and above	
Hydraulic Test	100% testing according to MSS SP-81 (respectively AWWA C520)	
	Shell	1.5*PN
	Packing	1.1*PN
	Seat	2.8 bar and maximum allowable differential pressure
DF Series are bi-directional up to 10 bar.		

## DF Series -Square Type

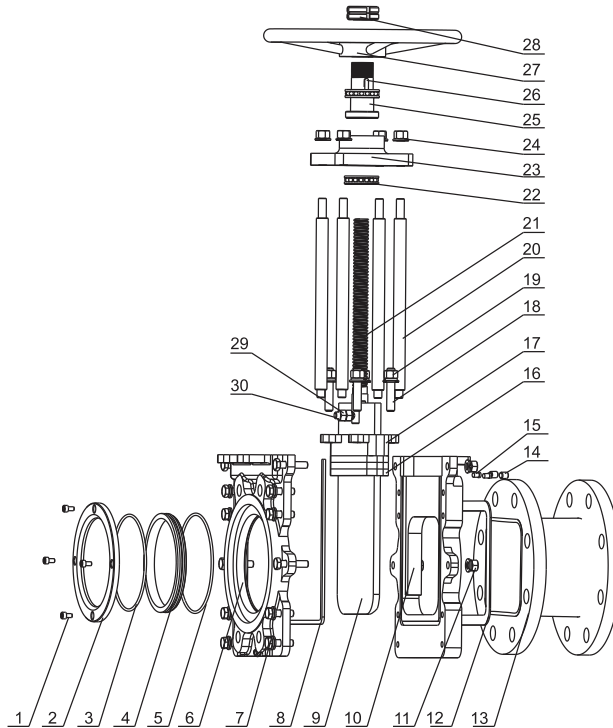

DF Series with Handwheel

### Parts List

No.	Parts Name	Materials	Qty.	No.	Parts Name	Materials	Qty.
1	Hexagon Socket Head Cap Screws	SS304	-	16	Packing	PTFE	1
2	Sealing Cap	SS304 / SS316	2	17	Gland Packing	CF8 / CF8M / WCB	1
3	O-Ring	NBR / Viton	2	18	Stud	SS304	-
4	Seat	SS304 / SS316 + Cr	2	19	Hexagon Nut	SS304	-
5	O-Ring	NBR / Viton	2	20	Pillar	SS304 / 45# + Cr	4
6	Upper Body	CF8 / CF8M / WCB	1	21	Stem	SS304	1
7	Hexagon Bolt	SS304	-	22	Plain Bearing	GCr6	2
8	Sealing Rope	NBR	2	23	Square Plate	SS304	1
9	Gate	CF8 / SS316 / SS410 + Cr / N	1	24	Hexagon Nut	SS304	4
10	Lower Body	CF8 / CF8M / WCB	1	25	Driving Nut	SS304	1
11	Hexagon Nut	SS304	-	26	Flat Key	45#	1
12	Gasket	PTFE	1	27	Handwheel	WCB	1
13	Flange Converter	SS304 / SS316	1	28	Nut	45#	2
14	Screw	SS304	2	29	Connection Pin	SS304	1
15	Guiding Ring	Nylon	2	30	Hexagon Nut	SS304	2

## DF Series -Square Type

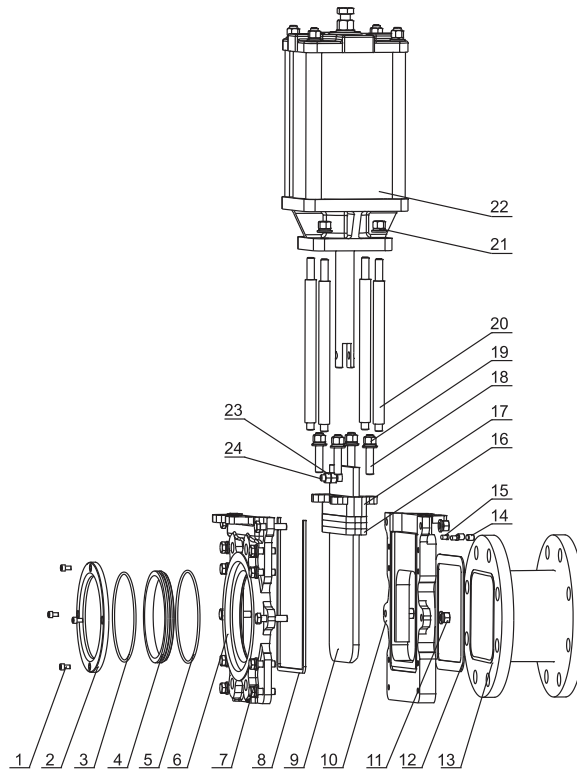

**DF Series with Pneumatic Cylinder**

### Parts List

No.	Parts Name	Materials	Qty.
1	Hexagon Socket Head Cap Screws	SS304	-
2	Sealing Cap	SS304 / SS316	2
3	O-Ring	NBR / Viton	2
4	Seat	SS304 / SS316 + Cr	2
5	O-Ring	NBR / Viton	2
6	Upper Body	CF8 / CF8M / WCB	1
7	Hexagon Bolt	SS304	-
8	Sealing Rope	NBR	2
9	Gate	SS304 / SS316 / SS410 + Cr / N	1
10	Lower Body	CF8 / CF8M / WCB	1
11	Hexagon Nut	SS304	-
12	Gasket	PTFE	1

No.	Parts Name	Materials	Qty.
13	Flange Converter	SS304 / SS316	1
14	Screw	SS304	2
15	Guiding Pin	Nylon	2
16	Packing	PTFE	1
17	Gland Packing	CF8 / CF8M / WCB	1
18	Stud	SS304	-
19	Hexagon Nut	SS304	-
20	Connection Rod	SS304 / 45# + Cr	4
21	Hexagon Nut	SS304	4
22	Pneumatic Actuator	/	1
23	Hexagon Nut	SS304	2
24	Connection Pin	SS304	1

## DF Series -Square Type

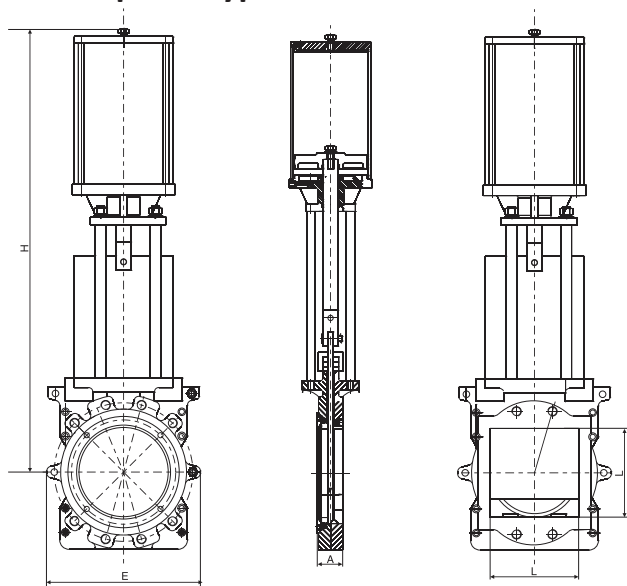

DF Series with Pneumatic Cylinder

### Dimensions

Size		Main Dimension (mm)			
NPS	DN	A	L	E	H
4"	100	51	100	220	650
5"	125	57	125	250	730
6"	150	57	150	270	820
8"	200	70	200	350	1040
10"	250	70	250	410	1230
12"	300	76	300	470	1390
14"	350	76	350	550	1590
16"	400	89	400	620	1750

## Square Face

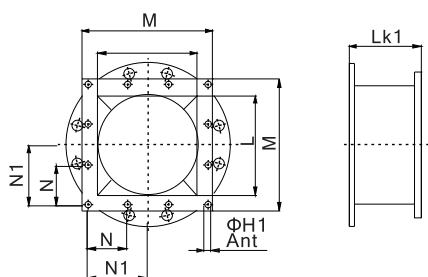

### Dimensions

Size		Main Dimension (mm)							
NPS	DN	L	M	N	N1	H1	Ant	Lk1	D1
4"	100	100	180	70	70	14	8	90	100
6"	150	150	230	95	95	14	8	140	150
8"	200	200	280	122.5	122.5	14	8	140	200
10"	250	250	340	150	150	14	8	150	250
12"	300	300	400	124	186	14	12	167	300
14"	350	350	450	137	205.5	18	12	165	350
16"	400	400	500	154	231	18	12	155	400

## Flange Face

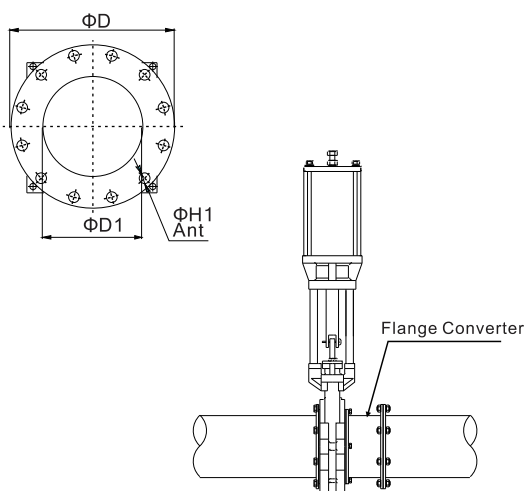

### Dimensions

Size		Main Dimension (mm)						
NPS	DN	D	R	V	V/2	ØH2	Ant	
4"	100	220	90	45	22.5	18	8	
6"	150	285	120	45	22.5	22	8	
8"	200	340	147.5	45	22.5	22	8	
10"	250	395	175	30	15	22	12	
12"	300	445	200	30	15	22	12	
14"	350	505	230	22.2	11.25	22	16	
16"	400	565	257.5	22.5	11.25	26	16	

Size		Main Dimension (mm)						
NPS	DN	D	R	V	V/2	ØH2	Ant	
4"	100	224	224	45	22.5	18	8	
6"	150	280	280	45	22.5	22	8	
8"	200	340	340	45	22.5	22	8	
10"	250	405	405	30	15	22	12	
12"	300	480	480	30	15	26	12	
14"	350	530	530	30	15	30	12	
16"	400	597	597	22.5	11.25	30	16	

Size		Main Dimension (mm)						
NPS	DN	D	R	V	V/2	ØH2	Ant	
4"	100	224	224	45	19	19	8	
6"	150	280	280	45	23	23	8	
8"	200	340	340	30	23	23	12	
10"	250	405	405	30	25	25	12	
12"	300	480	480	22.5	25	25	6	
14"	350	530	530	22.5	22	22	16	
16"	400	550	550	22.5	27	27	16	

Installation of square knife gate valve into a pipeline, requires special adapter flange for the square side of the valve. One side of the adapter needs square flange compatible to the valve, and one end to match the piping flange.



**VAHN-TECH International Inc.**

10-755 Queensway East, Mississauga, Ontario L4Y 4C5, Canada  
Tel.: +1 416 342 0001 E-mail: [info@vahn-tech.com](mailto:info@vahn-tech.com)

[www.vahn-tech.com](http://www.vahn-tech.com)