



RACK & PINION PNEUMATIC ACTUATOR



Intertek



VAHN-TECH International Inc., headquartered in Toronto, Canada is a unique company within the Flow Control Industry.

- ✿ 'vt' brand = high quality certified products (API, NSF, CSA, WRAS etc.)
- ✿ Valves, Actuators and Accessories – all 'vt' branded
- ✿ Width and Depth of Product Offerings
- ✿ Flexibility to customize products to customer needs
- ✿ Specialized user-friendly products including large sizes
- ✿ Quick Response
- ✿ Reduced Delivery times
- ✿ Efficient after sales service
- ✿ Competitive Pricing

VAHN-TECH International Inc. is a customer focused organization based on “Value-Add” and “Quality Service” principles. Achieving long term partnership with our customers and being their supplier of choice is our prime mission.

We develop, manufacture and market VAHN-TECH (vt) branded Valves, Actuators, Automatic Control Valves and Accessories for variety of Industrial Applications. Our product range includes:



Oil and Gas



Water and Sewage,
Desalination



Chemicals



Paper and Pulp



Irrigation



Power Plants



Various
Industrial Applications

We can supply all types of valves with following materials of construction like:

Ductile Iron, Cast Iron, Carbon Steel, Stainless Steel – SS304, SS304L, SS316, SS316L, Duplex Stainless Steel, Super Duplex, Alloy, Monel and Inconel with variety of seating and stem configurations.



License Number 60-1724



Intertek

Table of Contents

COMPACT PNEUMATIC ACTUATOR 4x4

Key Advantages	1
Design Features	2
General Features	3
Parts & Identification	4
Operations	5
Actuation Sizing Guide	6
Technical Data	9
How To Order	17

No ring groove on the top of drive shaft

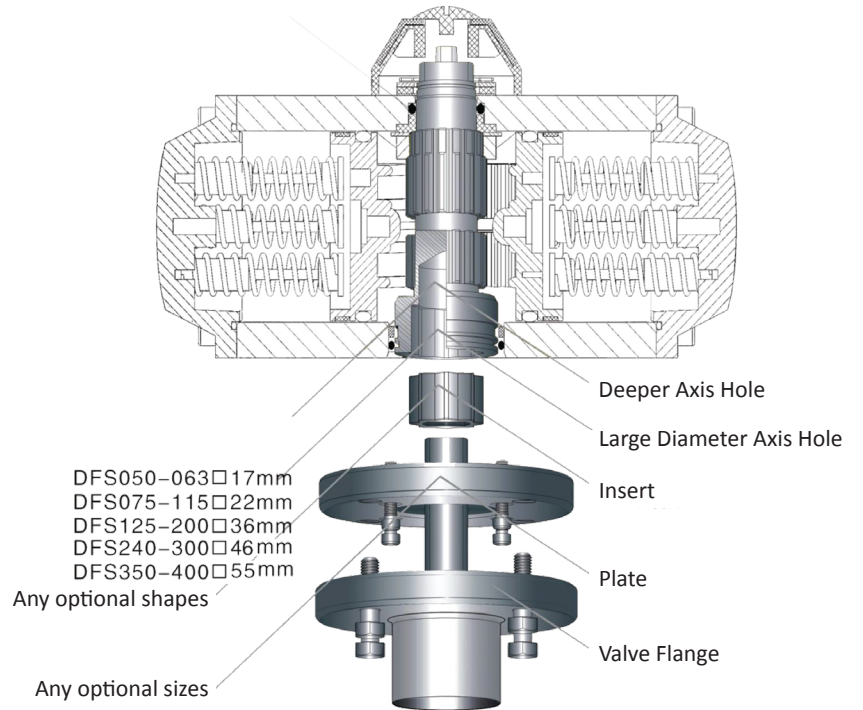

Patent No: ZL200930382594.7



DESIGN & CONSTRUCTION

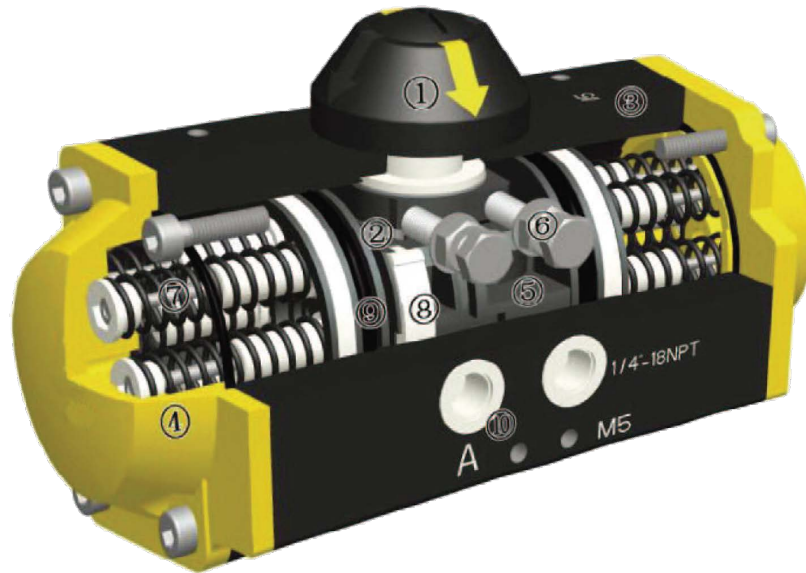

1. Indicator

Indicator according to VID/VIE 3845 is convenient for mounting accessories such as limit switch box, positioner and etc.

2. Pinion

The design of the nickel-plated alloy steel integrated forging pinion drive is according the NAMUR, ISO 5211 and DIN 3337 standards.

3. Actuator Body

Is made up from high quality anodized aluminum profiles. It is further protected by epoxy polyester coating. Upon request special finishes, e.g. PTFE coating, nickel plating or special color coatings are available.

End Cap

4. Made from anodized aluminum followed by epoxy polyester coating. Other surface treatments are available, e.g. PTFE and Nickel planting as well as other colors.

Piston

5. Manufactured from Die-Cast Aluminum and treated by anodized hardening process. Symmetric mounting of the piston helps to ensure easy maintenance. Reverse action requirements can be achieved by inverting the pistons.

Adjusting Bolt

6. The two independent adjustment bolts can adjust opening and closing of the mounted valve within $\pm 5^\circ$.

Spring

7. Preloaded high grade springs that are treated with epoxy resins finishing coat are used to different torque requirements can be achieved by changing quantity of springs in each assembly.

Piston Ring

8. Manufactured from low friction durable material Polyoxymethylene. These can be easily replaced during maintenance purposes.

9. O-ring

NBR Rubber O-rings provide trouble-free operation at standard temperature ranges.

10. Air Connection

Conforms to NAMUR Standards

*Special materials are available upon request.

*VAHN-TECH International Inc. reserves the right to change the technical data without prior notice.

OPERATIONS

The standard rotation is clockwise to close; counter-clockwise rotation is obtained when Port A is pressurized.

Double Acting Operation Function Top View (Standard Rotation)

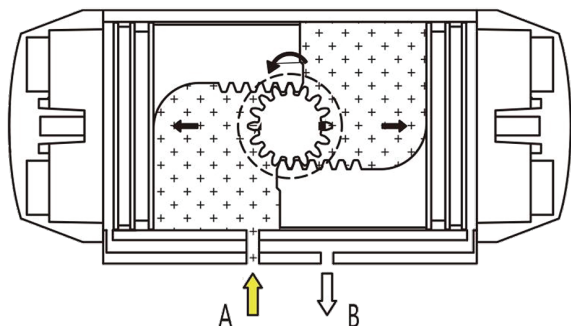

CCW

Air supplied to Port A forces the pistons apart and toward end positions, with exhaust air exiting at Port B, a counter-clockwise rotation is obtained.

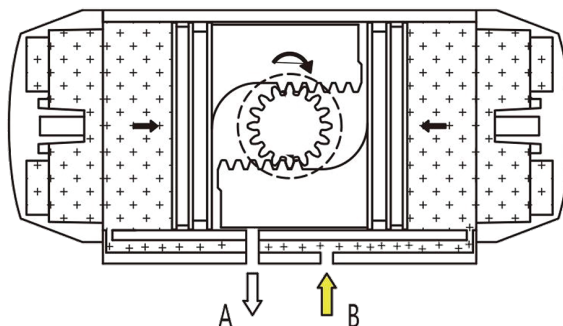

CW

Air supplied to Port B forces the pistons together with exhaust air existing at Port A, a clockwise rotation is obtained.

Simple Acting Operation Function Top View (Standard Rotation)

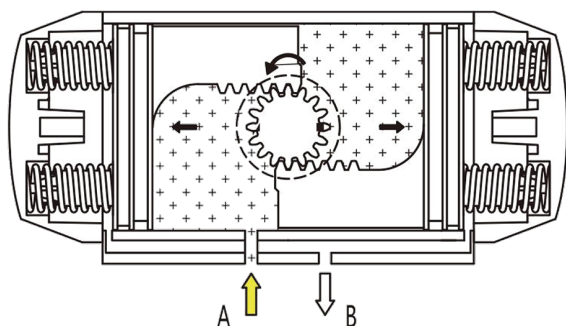

CCW

Air supplied to Port A forces the pistons apart and toward end positions, compressing the springs with exhaust air exiting at Port B, a counter-clockwise rotation is obtained.

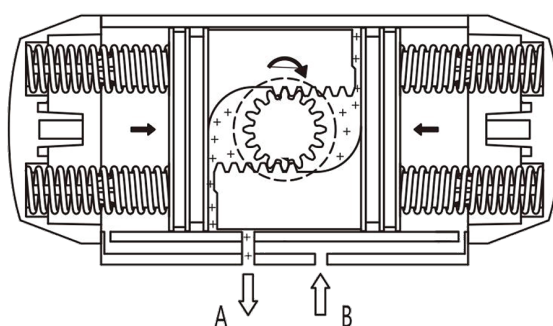

CW

On loss of air pressure (air or electric failure) at Port A allows the springs to force the positions to the center position with exhaust air exiting at Port A, a clockwise rotation is obtained.

EXPLODED VIEW

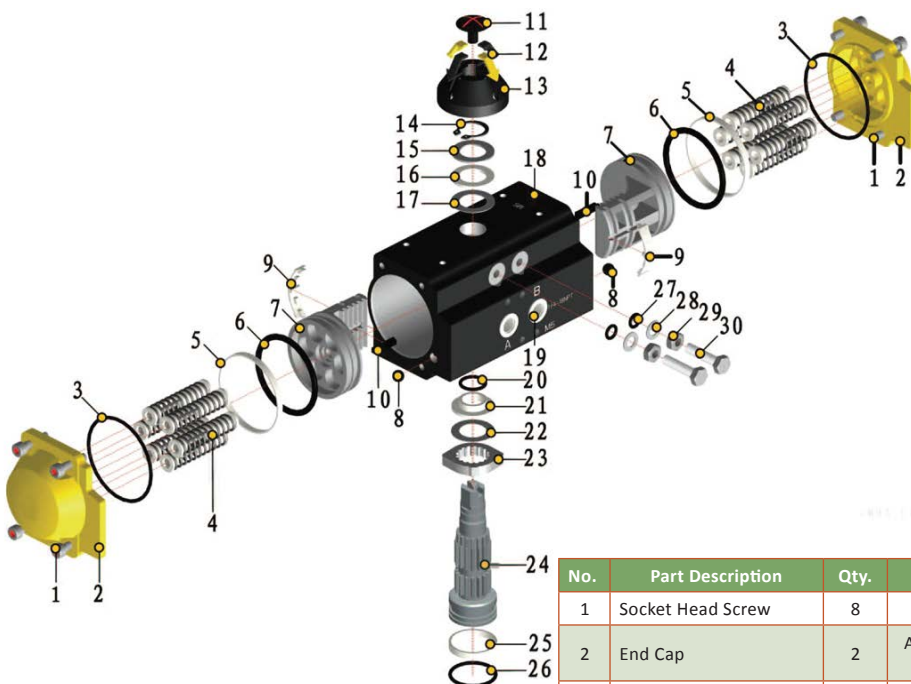

1. Top mounting connection is in line with VDI/VDE 3845 Standards, permitting direct installation of accessories such as positioners or limit switch box.
2. Bottom mounting connection is in line with ISO 5211 and DIN 3337 Standards.
3. Air supply connection is in line with VDI/VDE 3845 and NAMUR Standards to provide ease of installation of solenoid valves.

No.	Part Description	Qty.	Materials	Surface Treated	Optional Material
1	Socket Head Screw	8	SUS 304	-	-
2	End Cap	2	AL 380 ≤ DFS 200 WCB ≤ DFS 240	Anode Hardening + Polyester Coating	CF8 / CF8M
3	O-ring (Cylinder Head)	2	NBR Rubber	-	Viton / Silicone Rubber
4	Spring	2-12	Spring Sheet	Epoxy Resin Coating	-
5	Piston Ring	2	POM	-	-
6	O-ring (Piston)	2	NBR Rubber	-	Viton / Silicone Rubber
7	Piston	2	AL 380	Anode Hardening	-
8	Stopper	2	NBR Rubber	-	Viton / Silicone Rubber
9	Guide Ring	2	PA6	-	-
10	Guide Block	2	PA6	-	-
11	Indicator Bolt	1	ABS	-	-
12	Indicator Arrowhead	4	ABS	-	-
13	Indicator	1	ABS	-	-
14	Snap Ring	1	Stainless Steel	-	-
15	Washer	1	SUS 304	-	-
16	Disc Bearing	1	POM	-	-
17	Washer	1	SUS 304	-	-
18	Body	1	AL 6063-T6	Anode Hardening + Polyester Coating	CF8 / CF8M
19	Plug	2	PVC	-	-
20	O-ring (Pinion Top)	1	NBR Rubber	-	Viton / Silicone Rubber
21	Bearing (Pinion Top)	1	POM	-	-
22	Disc Bearing	1	SUS 304	-	-
23	Stroke Adjustment Stop	1	SAE 1020	Nickel Plated	CF8 / CF8M
24	Pinion Shaft	1	SAE 1045	Nickel Plated	SUS 304 / SUS 316
25	Bearing (Pinion Bottom)	1	POM	-	-
26	O-ring (Pinion Bottom)	1	NBR Rubber	-	Viton / Silicone Rubber
27	O-ring (Adjusting Bolt)	2	NBR Rubber	-	Viton / Silicone Rubber
28	Metal Washer	2	SUS 304	-	-
29	Nut	2	SUS 304	-	-
30	Adjusting Bolt	2	SUS 304	-	-

DIMENSIONS VT-DFS032 - VT-DFS400

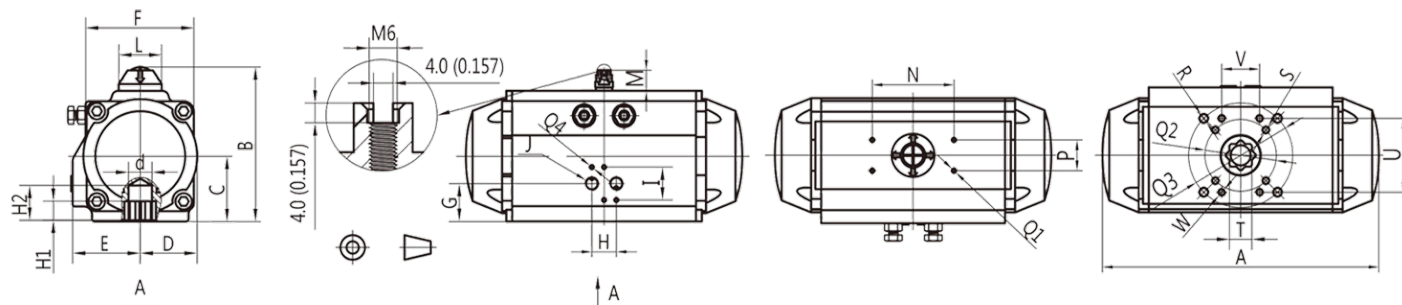

Unit: mm

Model	A	B	C	D	E	F	G	H	I	J	L	M	N	P	Q1	Q2	Q3	Q4	R	S	T	H1	d	H2	U	V	W
VT-DFS032	3.23	2.83	1.22	0.81	1.18	1.99	1.02	0.94	1.26	NPT 1/8"	Ø1.18	0.79	1.00	1.00	M5	Ø1.42	-	M5	-	4-M5	0.35	0.43	-	-	-	-	-
VT-DFS040	4.29	2.95	1.10	1.06	1.30	2.36	1.10	0.94	1.26	NPT 1/8"	Ø1.18	0.79	1.61	1.18	M5	Ø1.97	Ø1.65	M5	4-M6	4-M5	0.35	0.43	-	-	-	-	-
VT-DFS050	5.83	3.58	1.34	1.14	1.61	2.09	1.02	0.94	1.26	NPT 1/4"	Ø1.57	0.79	3.15	1.18	M5	Ø1.65	-	M5	-	4-M5	0.67	0.47	Ø0.56	1.26	-	-	-
VT-DFS063	6.26	4.21	1.65	1.42	1.85	2.60	1.18	0.94	1.26	NPT 1/4"	Ø1.57	0.79	3.15	1.18	M5	Ø1.97	-	M5	-	4-M6	0.67	0.63	Ø0.56	1.34	-	-	-
VT-DFS075	8.39	4.88	2.01	1.73	2.09	3.23	1.14	0.94	1.26	NPT 1/4"	Ø1.57	0.79	3.15	1.18	M5	Ø1.97	Ø2.76	M5	4-M8	4-M6	0.87	0.75	Ø0.77	1.34	-	-	-
VT-DFS085	9.80	5.43	2.28	1.93	2.24	3.62	1.26	0.94	1.26	NPT 1/4"	Ø1.57	0.79	3.15	1.18	M5	Ø1.97	Ø2.76	M5	4-M8	4-M6	0.87	0.75	Ø0.77	1.34	-	-	-
VT-DFS100	10.67	5.87	2.52	2.20	2.60	4.17	1.46	0.94	1.26	NPT 1/4"	Ø1.57	0.79	3.15	1.18	M5	Ø2.76	Ø4.02	M5	4-M10	4-M8	0.87	0.91	Ø0.91	1.89	2.83	1.46	M8
VT-DFS115	12.40	6.89	2.87	2.52	3.03	4.76	1.46	0.94	1.26	NPT 1/4"	Ø2.36	1.18	3.15	1.18	M5	Ø2.76	Ø4.02	M5	4-M10	4-M8	0.87	0.91	Ø0.91	1.89	2.83	1.46	M8
VT-DFS125	13.62	7.48	3.11	2.72	3.23	5.12	1.81	0.94	1.26	NPT 1/4"	Ø2.36	1.18	3.15	1.18	M5	Ø4.02	-	M5	-	4-M10	1.42	1.14	Ø1.42	2.56	2.83	1.46	M8
VT-DFS145	16.22	8.27	3.46	3.15	3.62	5.87	2.09	0.94	1.26	NPT 1/4"	Ø2.36	1.18	3.15	1.18	M5	Ø4.02	Ø4.92	M5	4-M12	4-M10	1.42	1.14	Ø1.42	2.56	2.83	1.46	M8
VT-DFS160	17.44	9.06	3.86	3.46	3.86	6.30	2.05	0.94	1.26	NPT 1/4"	Ø2.36	1.18	3.15	1.18	M5	Ø4.02	Ø4.92	M5	4-M12	4-M10	1.42	1.14	Ø1.42	2.56	2.83	1.46	M8
VT-DFS180	19.37	10.00	4.33	3.90	4.17	7.09	2.36	0.94	1.26	NPT 1/4"	Ø3.15	1.18	3.15	1.18	M5	Ø4.02	Ø5.51	M5	4-M16	4-M10	1.42	1.65	Ø1.50	3.62	3.9	2.09	M10
VT-DFS200	21.54	10.91	4.80	4.29	4.41	7.80	2.60	0.94	1.26	NPT 1/4"	Ø3.15	1.18	5.12	1.18	M5	Ø4.02	Ø5.51	M5	4-M16	4-M10	1.42	1.65	Ø1.50	3.62	3.9	2.09	M10
VT-DFS240	24.17	13.62	5.75	5.16	5.16	9.09	2.76	1.57	1.77	NPT 3/8"	Ø3.15	1.97	5.12	1.18	M5	Ø4.92	Ø6.50	M6	4-M20	4-M12	1.81	1.97	Ø1.89	3.62	-	-	-
VT-DFS265	28.70	15.28	6.57	5.79	5.79	10.00	3.54	1.57	1.77	NPT 3/8"	Ø3.15	1.97	5.12	1.18	M5	-	Ø6.50	M6	4-M20	-	1.81	1.97	Ø1.89	3.62	-	-	-
VT-DFS300	33.03	16.06	7.01	6.38	6.81	11.42	3.35	1.57	1.77	NPT 1/2"	Ø3.15	1.97	5.12	1.18	M5	-	Ø6.50	M6	4-M20	-	1.81	1.97	Ø1.89	3.62	-	-	-
VT-DFS350	35.43	18.11	8.07	7.44	7.68	13.23	3.62	1.57	1.77	NPT 1/2"	Ø2.95	1.97	5.12	1.18	M5	-	Ø10	M6	4-M16	-	2.17	2.36	Ø2.17	3.94	-	-	-
VT-DFS400	45.59	20.35	9.21	10.24	10.24	13.03	9.17	1.57	1.77	NPT 1/2"	Ø2.95	1.97	5.12	1.18	M5	-	Ø10	M6	4-M16	-	2.17	2.36	Ø2.17	3.94	-	-	-

Unit: inch

Model	A	B	C	D	E	F	G	H	I	J	L	M	N	P	Q1	Q2	Q3	Q4	R	S	T	H1	d	H2	U	V	W
VT-DFS032	3.23	2.83	1.22	0.81	1.18	1.99	1.02	0.94	1.26	NPT 1/8"	Ø1.18	0.79	1.00	1.00	M5	Ø1.42	-	M5	-	4-M5	0.35	0.43	-	-	-	-	-
VT-DFS040	4.29	2.95	1.10	1.06	1.30	2.36	1.10	0.94	1.26	NPT 1/8"	Ø1.18	0.79	1.61	1.18	M5	Ø1.97	Ø1.65	M5	4-M6	4-M5	0.35	0.43	-	-	-	-	-
VT-DFS050	5.83	3.58	1.34	1.14	1.61	2.09	1.02	0.94	1.26	NPT 1/4"	Ø1.57	0.79	3.15	1.18	M5	Ø1.65	-	M5	-	4-M5	0.67	0.47	Ø0.56	1.26	-	-	-
VT-DFS063	6.26	4.21	1.65	1.42	1.85	2.60	1.18	0.94	1.26	NPT 1/4"	Ø1.57	0.79	3.15	1.18	M5	Ø1.97	-	M5	-	4-M6	0.67	0.63	Ø0.56	1.34	-	-	-
VT-DFS075	8.39	4.88	2.01	1.73	2.09	3.23	1.14	0.94	1.26	NPT 1/4"	Ø1.57	0.79	3.15	1.18	M5	Ø1.97	Ø2.76	M5	4-M8	4-M6	0.87	0.75	Ø0.77	1.34	-	-	-
VT-DFS085	9.80	5.43	2.28	1.93	2.24	3.62	1.26	0.94	1.26	NPT 1/4"	Ø1.57	0.79	3.15	1.18	M5	Ø1.97	Ø2.76	M5	4-M8	4-M6	0.87	0.75	Ø0.77	1.34	-	-	-
VT-DFS100	10.67	5.87	2.52	2.20	2.60	4.17	1.46	0.94	1.26	NPT 1/4"	Ø1.57	0.79	3.15	1.18	M5	Ø2.76	Ø4.02	M5	4-M10	4-M8	0.87	0.91	Ø0.91	1.89	2.83	1.46	M8
VT-DFS115	12.40	6.89	2.87	2.52	3.03	4.76	1.46	0.94	1.26	NPT 1/4"	Ø2.36	1.18	3.15	1.18	M5	Ø2.76	Ø4.02	M5	4-M10	4-M8	0.87	0.91	Ø0.91	1.89	2.83	1.46	M8
VT-DFS125	13.62	7.48	3.11	2.72	3.23	5.12	1.81	0.94	1.26	NPT 1/4"	Ø2.36	1.18	3.15	1.18	M5	Ø4.02	-	M5	-	4-M10	1.42	1.14	Ø1.42	2.56	2.83	1.46	M8
VT-DFS145	16.22	8.27	3.46	3.15	3.62	5.87	2.09	0.94	1.26	NPT 1/4"	Ø2.36	1.18	3.15	1.18	M5	Ø4.02	Ø4.92	M5	4-M12	4-M10	1.42	1.14	Ø1.42	2.56	2.83	1.46	M8
VT-DFS160	17.44	9.06	3.86	3.46	3.86	6.30	2.05	0.94	1.26	NPT 1/4"	Ø2.36	1.18	3.15	1.18	M5	Ø4.02	Ø4.92	M5	4-M12	4-M10	1.42	1.14	Ø1.42	2.56	2.83	1.46	M8
VT-DFS180	19.37	10.00	4.33	3.90	4.17	7.09	2.36	0.94	1.26	NPT 1/4"	Ø3.15	1.18	3.15	1.18	M5	Ø4.02	Ø5.51	M5	4-M16	4-M10	1.42	1.65	Ø1.50	3.62	3.9	2.09	M10
VT-DFS200	21.54	10.91	4.80	4.29	4.41	7.80	2.60	0.94	1.26	NPT 1/4"	Ø3.15	1.18	5.12	1.18	M5	Ø4.02	Ø5.51	M5	4-M16	4-M10	1.42	1.65	Ø1.50	3.62	3.9	2.09	M10
VT-DFS240	24.17	13.62	5.75	5.16	5.16	9.09	2.76	1.57	1.77	NPT 3/8"	Ø3.15	1.97	5.12	1.18	M5	Ø4.92	Ø6.50	M6	4-M20	4-M12	1.81	1.97	Ø1.89	3.62	-	-	-
VT-DFS265	28.70	15.28	6.57	5.79	5.79	10.00	3.54	1.57	1.77	NPT 3/8"	Ø3.15	1.97	5.12	1.18	M5	-	Ø6.50	M6	4-M20	-	1.81	1.97	Ø1.89	3.62	-	-	-
VT-DFS300	33.03	16.06	7.01	6.38	6.81	11.42	3.35	1.57	1.77	NPT 1/2"	Ø3.15	1.97	5.12	1.18	M5	-	Ø6.50	M6	4-M20	-	1.81	1.97	Ø1.89	3.62	-	-	-
VT-DFS350	35.43	18.11	8.07	7.44	7.68	13.23	3.62	1.57	1.77	NPT 1/2"	Ø2.95	1.97	5.12	1.18	M5	-	Ø10	M6	4-M16	-	2.17	2.36	Ø2.17	3.94	-	-	-
VT-DFS400	45.59	20.35	9.21	10.24	10.24	13.03	9.17	1.57	1.77	NPT 1/2"	Ø2.95	1.97	5.12	1.18	M5	-	Ø10	M6	4-M16	-	2.17	2.36	Ø2.17	3.94	-	-	-

VAHN-TECH International Inc. reserves the right to change the technical data without prior notice.

WEIGHT & AIR CONSUMPTION

Unit: mm

Model	Body Diameter	Air Consumption Per Stroke Actual Volume		Opening Time (DA)	Closing Time (DA)	Approximate Weight (DA)
	Ø (mm)	CCW (L)	CW (L)	S (sec.)	S (sec.)	kg
VT-DFS032	32	0.015	0.034	0.13	0.14	0.322
VT-DFS040	40	0.032	0.068	0.14	0.16	0.695
VT-DFS050	50	0.08	0.13	0.17	0.19	1.08
VT-DFS063	63	0.15	0.25	0.19	0.22	1.55
VT-DFS075	75	0.3	0.48	0.23	0.27	2.75
VT-DFS085	88	0.5	0.73	0.33	0.35	3.78
VT-DFS100	100	0.75	1.08	0.42	0.48	5.3
VT-DFS115	115	1.19	1.8	0.72	0.93	8.4
VT-DFS125	125	1.55	2.18	0.84	1.09	9.93
VT-DFS145	145	2.4	3.55	1.32	1.42	14.1
VT-DFS160	160	3.2	4.72	1.6	2	18.35
VT-DFS180	180	4.3	6.8	2	2.4	25
VT-DFS200	200	5.87	9.53	2.7	3.5	35
VT-DFS240	240	10	15	3.5	4.5	63
VT-DFS265	270	15	23	4.5	5	79
VT-DFS300	300	21.1	30.5	8.8	12.7	135.8
VT-DFS350	350	30.8	44.4	13	19	234.3
VT-DFS400	400	48.3	69.6	20	29	338

Unit: inch

Model	Body Diameter	Air Consumption Per Stroke Actual Volume		Opening Time (DA)	Closing Time (DA)	Approximate Weight (DA)
	Ø (mm)	CCW (L)	CW (L)	S (sec.)	S (sec.)	kg
VT-DFS032	1.26	0.015	0.034	0.13	0.14	0.71
VT-DFS040	1.57	0.032	0.68	0.14	0.16	1.53
VT-DFS050	1.97	0.08	0.13	0.17	0.19	2.38
VT-DFS063	2.48	0.15	0.25	0.19	0.22	3.42
VT-DFS075	2.95	0.3	0.48	0.23	0.27	6.06
VT-DFS085	3.46	0.5	0.73	0.33	0.35	8.33
VT-DFS100	3.94	0.75	1.08	0.42	0.48	11.68
VT-DFS115	4.53	1.19	1.8	0.72	0.93	18.5
VT-DFS125	4.92	1.55	2.18	0.84	1.09	21.89
VT-DFS145	5.71	2.4	3.55	1.32	1.42	31.08
VT-DFS160	6.3	3.2	4.72	1.6	2	40.45
VT-DFS180	7.09	4.3	6.8	2	2.4	55.12
VT-DFS200	7.87	5.87	9.53	2.7	3.5	77.16
VT-DFS240	9.45	10	15	3.5	4.5	138.89
VT-DFS265	10.63	15	23	4.5	5	174.16
VT-DFS300	11.81	21.1	30.5	8.8	12.7	299.39
VT-DFS350	13.78	30.8	44.4	13	19	516.54
VT-DFS400	15.75	48.3	69.6	20	29	745.16

The above indicated travel times of the actuator, are obtained under the following conditions:

- 1 Room Temperature
- 2 Actuator Stroke 90°
- 3 Solenoid Valve with Orifice of 4mm and flow capacity QN 400L/min.
- 4 Inside Pipe Diameter 5mm
- 5 Medium: Clean Air
- 6 Air supply pressure 5.5 Bar (79.75 PSI)
- 7 Actuator without external resistance load.

OUTPUT TORQUE OF DOUBLE ACTING ACTUATOR

Unit: N.m

Model	Air Pressure						
	3.0 Bar	4.0 Bar	5.0 Bar	5.5 Bar	6.0 Bar	7.0 Bar	8.0 Bar
VT-DFS032	3.2	4.5	5.9	6.6	7.2	8.5	9.8
VT-DFS040	5	7	9	10	11	13	15
VT-DFS050	9.5	12	15.8	17.5	19	23	26.5
VT-DFS063	16	21.5	28.7	31	34	39	46
VT-DFS075	34	47	58.5	63	69	80.5	91
VT-DFS085	53	70	88	98	106	124	145
VT-DFS100	76.5	104	127	142	155	184	214
VT-DFS115	129	170	215	236	258	301	344
VT-DFS125	163	210	268	300	328	385	442
VT-DFS145	230	315	420	462	504	590	690
VT-DFS160	350	450	560	625	675	788	910
VT-DFS180	445	607	760	848	910	1064	1237
VT-DFS200	625	840	1058	1165	1260	1462	1681
VT-DFS240	1070	1435	1785	1970	2150	2508	2865
VT-DFS265	1745	2320	2900	3200	3500	4080	4670
VT-DFS300	2195	2927	3681	4025	4391	5122	5854
VT-DFS350	3205	4274	5369	5876	6411	7479	8547
VT-DFS400	5024	6698	8415	9210	10048	11722	13397

Unit: in-lb

Model	Air Pressure						
	40 PSI	60 PSI	70 PSI	80 PSI	90 PSI	100 PSI	120 PSI
VT-DFS032	26	41	51	59	67	76	92
VT-DFS040	41	64	77	89	101	113	137
VT-DFS050	77	110	135	155	174	201	243
VT-DFS063	130	197	245	275	311	340	421
VT-DFS075	277	430	500	559	632	702	833
VT-DFS085	431	641	752	870	970	1081	1328
VT-DFS100	623	952	1085	1261	1419	1604	1959
VT-DFS115	1050	1556	1837	2095	2362	2625	3149
VT-DFS125	1327	1923	2289	2664	3003	3357	4047
VT-DFS145	1872	2884	3588	4102	4862	5145	6317
VT-DFS160	2849	4120	4784	5549	6180	6871	8331
VT-DFS180	3622	557	6492	7529	8331	9278	11325
VT-DFS200	5087	7690	9037	10344	11536	12748	15390
VT-DFS240	8709	13138	15248	17492	19684	21869	26230
VT-DFS265	14203	21240	24772	28413	32044	3557	42755
VT-DFS300	17865	26798	31443	35738	40201	4463	53595
VT-DFS350	26086	39130	45862	52173	58695	65215	78251
VT-DFS400	40891	61322	71881	81775	91993	102213	122654

OUTPUT TORQUE OF SPRING RETURN ACTUATOR

Unit: N.m

Model	Spring Qty.	3.0 Bar		4.0 Bar		5.0 Bar		5.5 Bar		6.0 Bar		7.0 Bar		8.0 Bar		Spring Return	
		0°	90°	0°	90°	0°	90°	0°	90°	0°	90°	0°	90°	0°	90°	0°	90°
VT-DFS040	2	-	-	-	-	6.0	4.0	7.0	5.0	8.0	6.0	10.0	8.0	12.0	10.0	3.0	5.0
	4	-	-	-	-	-	-	-	-	6.0	2.0	8.0	4.0	10.0	6.0	5.0	9.0
VT-DFS050	5	6.5	4.8	9.0	7.3	12.8	11.1	14.5	12.8	16.0	14.3	20.0	18.3	23.5	21.8	3.0	4.7
	6	5.7	3.8	8.2	6.3	12.0	10.1	13.7	11.8	15.2	13.3	19.2	17.3	22.7	20.8	3.8	5.7
	7	5.0	2.8	7.5	5.3	11.3	9.1	13.0	10.8	14.5	12.3	18.5	16.3	22.0	19.8	4.5	6.7
	8	-	-	6.7	4.2	10.5	8.0	12.2	9.7	13.7	11.2	17.7	15.2	21.2	18.7	5.3	7.8
	9	-	-	6.0	3.3	9.8	7.1	11.5	8.8	13.0	10.3	17.0	14.3	20.5	17.8	6.0	8.7
	10	-	-	-	-	9.1	6.2	10.8	7.9	12.3	9.4	16.3	13.4	19.8	16.9	6.7	9.6
	11	-	-	-	-	8.3	5.1	10.0	6.8	11.5	8.4	15.5	12.3	19.0	15.8	7.5	10.7
VT-DFS063	5	10.3	7.4	15.8	12.9	23.0	20.1	25.3	22.4	28.3	25.4	33.3	30.4	40.3	37.4	5.7	8.6
	6	9.2	5.6	14.7	11.1	21.9	18.3	24.2	20.6	27.2	23.6	32.2	28.6	39.2	35.6	6.8	10.4
	7	8.1	3.8	13.6	9.3	20.8	16.5	23.1	18.8	26.1	21.8	31.1	26.8	38.1	33.8	7.9	12.2
	8	-	-	12.4	7.7	19.6	14.9	21.9	17.2	24.9	20.2	29.9	25.2	36.9	32.2	9.1	13.8
	9	-	-	11.2	5.9	18.4	13.1	20.7	15.4	23.7	18.4	28.7	23.4	35.7	30.4	10.3	15.6
	10	-	-	10.0	4.1	17.2	11.3	19.5	13.6	22.5	16.6	27.5	21.6	34.5	28.6	11.5	17.4
	11	-	-	-	-	16.1	9.5	18.4	11.8	21.4	14.8	26.4	19.8	33.4	26.8	12.6	19.2
VT-DFS075	5.0	22.5	16.0	35.5	29.0	47.0	40.5	51.5	45.0	57.5	51.0	69.0	62.5	79.5	73.0	11.5	18.0
	6.0	20.5	12.5	33.5	25.5	45.0	37.0	49.5	41.5	55.5	47.5	67.0	59.0	77.5	69.5	13.5	21.5
	7.0	18.3	9.0	31.3	22.0	42.8	33.5	47.3	38.0	53.3	44.0	64.8	55.5	75.3	66.0	15.7	25.0
	8.0	-	-	29.0	18.5	40.5	30.0	45.0	34.5	51.0	40.5	62.5	52.0	73.0	62.5	18.0	28.5
	9.0	-	-	26.9	15.0	38.4	26.5	42.9	31.0	48.9	37.0	60.4	48.5	70.9	59.0	20.1	32.0
	10.0	-	-	24.7	11.5	36.2	23.0	40.7	27.5	46.7	33.5	58.2	45.0	68.7	55.5	22.3	35.5
	11.0	-	-	-	-	34.0	19.5	38.5	24.0	44.5	30.0	56.0	41.5	66.5	52.0	24.5	39.0
DFS085	5.0	34.2	23.0	51.2	40.0	69.2	58.0	79.2	68.0	87.2	76.0	105.2	94.0	126.2	115.0	18.8	30.0
	6.0	30.5	17.2	47.5	34.2	65.5	52.2	75.5	62.2	83.5	70.2	101.5	88.2	122.5	109.2	22.5	35.8
	7.0	26.8	11.4	43.8	28.4	61.8	46.4	71.8	56.4	79.8	64.4	97.8	82.4	118.8	103.4	26.2	41.6
	8.0	-	-	40.2	22.6	58.2	40.6	68.2	50.6	76.2	58.6	94.2	76.6	115.2	97.6	29.8	47.4
	9.0	-	-	36.6	16.8	54.6	34.8	64.6	44.8	72.6	52.8	90.6	70.8	111.6	91.8	33.4	53.2
	10.0	-	-	32.9	11.0	50.9	29.0	60.9	39.0	68.9	47.0	86.9	65.0	107.9	86.0	37.1	59.0
	11.0	-	-	-	-	47.2	23.2	57.2	33.2	65.2	41.2	83.2	59.2	104.2	80.2	40.8	64.8
VT-DFS100	5.0	51.4	37.5	78.9	65.0	101.9	88.0	116.9	103.0	129.9	116.0	158.9	145.0	188.9	175.0	25.1	39.0
	6.0	46.3	29.6	73.8	57.1	96.8	80.1	111.8	95.1	124.8	108.1	153.8	137.1	183.8	167.1	30.2	46.9
	7.0	41.2	21.7	68.7	49.2	91.7	72.2	106.7	87.2	119.7	100.2	148.7	129.2	178.7	159.2	35.3	54.8
	8.0	-	-	63.6	41.3	86.6	64.3	101.6	79.3	114.6	92.3	143.6	121.3	173.6	151.3	40.4	62.7
	9.0	-	-	58.5	33.4	81.5	56.4	96.5	71.4	109.5	84.4	138.5	113.4	168.5	143.4	45.5	70.6
	10.0	-	-	53.5	25.6	76.5	48.6	91.5	63.6	104.5	76.6	133.5	105.6	163.5	135.6	50.5	78.4
	11.0	-	-	-	-	71.4	40.7	86.4	55.7	99.4	68.7	128.4	97.7	158.4	127.7	55.6	86.3
VT-DFS115	5	88	63	131	106	174	149	195	170	217	192	260	235	303	279	41	66
	6	80	50	123	93	166	136	187	158	209	180	252	222	295	266	49	79
	7	72	37	115	80	158	123	179	145	200	166	244	209	287	252	57	92
	8	-	-	106	67	149	110	171	132	192	153	235	196	279	239	66	105
	9	-	-	98	54	141	97	163	118	184	140	227	183	270	226	74	118
	10	-	-	-	-	133	84	154	105	176	127	219	170	262	213	82	131
	11	-	-	-	-	125	71	146	92	168	114	211	157	254	200	90	144
VT-DFS125	5	112	82	159	129	217	187	249	219	277	247	334	304	391	361	51	81
	6	102	65	149	112	207	170	239	202	266.5	230	323.5	287	380.5	344	61.5	98
	7	91	49	138	96	196	154	228	186	256	214	313	271	370	328	72	114
	8	-	-	127	79	185	137	217	169	245	197	302	254	359	311	83	131
	9	-	-	117	62	175	120	207	152	234.5	180	291.5	237	348.5	294	93.5	148
	10	-	-	106	45	164	103	196	135	224	163	281	220	338	277	104	165
	11	-	-	-	-	154	87	186	119	213.5	147	270.5	204	327.5	261	114.5	181
VT-DFS145	5	149	103	234	188	339	293	381	335	450	404	509	463	609	563	81	127
	6	132	77	217	162	322	267	364	309	433	378	492	437	592	537	98	153
	7	115	51	200	136	305	241	347	283	416	352	475	411	575	511	115	179
	8	-	-	184	110	289	215	331	257	400	326	459	385	559	485	131	205
	9	-	-	167	85	272	190	314	232	383	301	442	360	542	460	148	230
	10	-	-	150	59	255	164	297	206	366	275	425	334	525	434	165	256
	11	-	-	-	-	239	138	281	180	350	249	409	308	509	408	181	282
12	-	-	-	-	223	112	265	154	334	223	393	282	493	382	197	308	

VAHN-TECH International Inc. reserves the right to change the technical data without prior notice.

OUTPUT TORQUE OF SPRING RETURN ACTUATOR

Unit: N.m

Model	Spring Qty.	3.0 Bar		4.0 Bar		5.0 Bar		5.5 Bar		6.0 Bar		7.0 Bar		8.0 Bar		Spring Return	
		0°	90°	0°	90°	0°	90°	0°	90°	0°	90°	0°	90°	0°	90°	0°	90°
VT-DFS160	5	240	185	340	285	450	395	515	460	565	510	678	623	800	745	110	165
	6	217	15	317	252	427	362	492	427	542	477	655	590	777	712	133	198
	7	194	118	294	218	404	328	469	393	519	443	632	556	754	678	156	232
	8	-	-	271	185	381	295	446	360	496	410	609	523	731	645	179	265
	9	-	-	249	151	359	261	424	326	474	376	587	489	709	611	201	299
	10	-	-	226	118	336	228	401	293	451	343	564	456	686	578	224	332
	11	-	-	-	-	313	194	378	259	428	309	541	422	663	544	247	366
12	-	-	-	-	291	161	356	226	406	276	519	389	641	511	269	399	
VT-DFS180	5	289	206	451	368	604	521	692	609	754	671	908	825	1081	998	156	239
	6	257	159	419	321	572	474	660	562	722	624	876	778	1049	951	188	286
	7	225	112	387	274	540	427	628	515	690	577	844	731	1017	904	220	333
	8	-	-	355	226	508	379	596	467	658	529	812	683	985	856	252	381
	9	-	-	324	179	477	332	565	420	627	482	781	636	954	809	283	428
	10	-	-	292	132	445	285	533	373	595	435	749	589	922	762	315	475
	11	-	-	-	-	414	238	502	326	564	388	718	542	891	715	346	522
12	-	-	-	-	382	191	470	279	532	341	686	495	859	668	378	569	
VT-DFS200	5	409	307	624	522	842	740	949	847	1044	942	1246	1144	1465	1363	216	318
	6	367	244	582	459	800	677	907	784	1002	879	1204	1081	1423	1300	258	381
	7	325	181	540	396	758	614	865	721	960	816	1162	1018	1381	1237	300	444
	8	-	-	498	334	716	552	823	659	918	754	1120	956	1339	1175	342	506
	9	-	-	455	272	673	490	780	597	875	692	1077	894	1296	1113	385	568
	10	-	-	412	209	630	427	737	534	832	629	1034	831	1253	1050	428	631
	11	-	-	-	-	588	365	695	472	790	567	992	769	1211	988	470	693
12	-	-	-	-	454	302	652	409	747	504	949	706	1168	925	513	756	
VT-DFS240	5	705	543	1070	908	1420	1258	1605	1443	1785	1623	2143	1981	2500	2338	365	527
	6	631	438	996	803	1346	1153	1531	1338	1711	1518	2069	1876	2426	2233	439	632
	7	558	331	923	696	1273	1046	1458	1231	1638	1413	1995	1772	2351	2128	512	739
	8	-	-	845	590	1199	940	1384	1125	1564	1308	1922	1667	2277	2023	586	845
	9	-	-	778	486	1128	836	1313	1021	1493	1203	1848	1563	2202	1918	657	949
	10	-	-	704	383	1054	733	1239	918	1419	198	1773	1458	2129	1812	731	1052
	11	-	-	-	-	980	627	1165	812	1345	994	1700	1352	2055	1708	805	1158
12	-	-	-	-	906	518	1091	703	1271	890	1625	1248	1980	1602	879	1267	
VT-DFS265	5	1203	945	1178	1520	2358	2100	2658	2400	2958	2700	3538	3280	4128	3870	542	800
	6	1092	790	1671	1363	2249	1940	2549	2240	2849	2540	3429	3120	4019	3710	65	955
	7	985	629	1564	1206	2140	1780	2449	2080	2470	2380	3320	2960	3910	3550	760	1116
	8	-	-	1457	1045	2031	1620	2330	1920	2631	2220	3211	2800	3801	3390	865	1275
	9	-	-	1350	886	1922	1460	2222	1760	2522	2060	3102	2640	3682	3230	980	1440
	10	-	-	1234	724	1813	1300	2113	1600	2413	1900	2993	2480	3583	3070	1086	1596
	11	-	-	-	-	1704	1140	2004	1440	2304	1740	2884	2320	3474	2910	119	1754
12	-	-	-	-	1600	990	1895	1280	2195	1580	2775	2160	3365	2750	1300	1910	
VT-DFS300	5	1457	1088	2189	1820	2943	2574	3287	2918	3653	3284	4384	4015	5116	4747	738	1107
	6	1310	868	2042	1600	2796	2354	3140	2698	3506	3064	4237	3795	4969	4527	885	1327
	7	1163	647	1895	1379	2649	2133	2993	2477	3359	2843	4090	3574	4822	4306	1032	1548
	8	-	-	1748	1158	2502	1912	2846	2256	3212	2622	3943	3353	4675	4085	1179	1769
	9	-	-	1600	937	2354	1691	2698	2035	3064	2401	3795	3132	7527	3864	1327	1990
	10	-	-	1453	716	2207	1470	2551	1814	2917	2180	3648	2911	4380	3643	1474	2211
	11	-	-	-	-	2060	1249	2404	1593	2770	1959	3501	2690	4233	3422	1621	2432
12	-	-	-	-	-	-	2256	1372	2622	1738	3353	2469	4085	3201	1769	2653	
VT-DFS350	5	2129	1591	3198	2660	4293	3755	4800	4262	5335	4797	6403	5865	7471	6933	1076	1614
	6	1914	1269	2983	2338	4078	3433	4585	3940	5120	4475	6188	4453	7256	6611	1291	1936
	7	1700	947	2769	2016	3864	3111	4371	3618	4906	4153	5974	5221	7042	6289	1505	2258
	8	-	-	2554	1694	3649	2789	4156	3296	4691	3831	5759	4899	6827	5967	1720	2580
	9	-	-	2339	1372	3434	2467	3941	2974	4476	3509	5544	4577	6612	5645	1935	2902
	10	-	-	2124	1050	3219	2145	3726	2652	4261	3187	5329	4255	6397	5323	2150	3224
	11	-	-	-	-	3005	1823	3512	2330	4047	2865	5115	3933	6183	5001	2364	3546
12	-	-	-	-	-	-	3297	2007	3832	2542	4900	3610	5968	4678	2579	3869	
VT-DFS400	5	3341	2499	5015	4173	6732	5890	7527	6685	8365	7523	10039	9197	11714	10872	1683	2525
	6	3004	1994	4678	3668	6395	5385	7190	6180	8028	7018	9702	8692	11377	10367	2020	3030
	7	2668	1489	4342	3163	6059	4880	6854	5675	7692	6513	9366	8187	11041	9862	2356	3535
	8	-	-	4005	2658	572	4375	6517	5170	7355	6008	9029	7682	10704	9357	2693	4040
	9	-	-	3669	2153	5386	3870	6181	4665	7019	5503	8693	7177	10368	8852	3029	4545
	10	-	-	3332	1648	5049	3365	5844	4160	6682	4998	8356	6672	10031	8347	3366	5050
	11	-	-	-	-	4712	2860	5507	3655	6345	4493	8019	6167	9694	7842	3703	5555
12	-	-	-	-	-	-	5171	3150	6009	3988	7683	5662	9358	7337	4039	6060	

OUTPUT TORQUE OF SPRING RETURN ACTUATOR

Unit: in-lb

Model	Spring Qty.	40 PSI		60 PSI		70 PSI		80 PSI		90 PSI		100 PSI		120 PSI		Spring Return	
		0°	90°	0°	90°	0°	90°	0°	90°	0°	90°	0°	90°	0°	90°	0°	90°
VT-DFS040	2	-	-	-	-	51	33	62	45	73	56	87	69	110	93	27	44
	4	-	-	-	-	-	-	-	-	55	21	70	34	92	58	44	80
VT-DFS050	5	53	39	82	67	109	95	129	114	146	131	174	160	215	200	27	42
	6	46	31	75	58	103	86	122	105	139	122	167	151	208	190	34	50
	7	41	23	69	49	97	78	115	96	133	113	161	142	201	181	40	59
	8	-	-	61	38	90	68	108	86	125	10	154	133	194	171	47	69
	9	-	-	55	30	84	61	102	78	119	94	148	125	188	163	53	77
	10	-	-	-	-	78	53	96	70	113	86	142	117	181	155	59	85
	11	-	-	-	-	71	44	89	60	105	76	135	107	174	145	66	95
12	-	-	-	-	64	34	82	51	98	66	128	98	167	135	73	104	
VT-DFS063	5	84	60	145	118	197	172	225	199	259	233	290	265	369	342	50	76
	6	75	46	135	102	187	156	215	183	249	216	281	249	359	326	60	92
	7	66	31	125	85	178	141	205	167	239	200	271	234	349	309	70	108
	8	-	-	114	70	167	127	194	153	228	185	261	220	338	295	81	122
	9	-	-	103	54	157	112	184	137	217	168	250	204	327	278	91	138
	10	-	-	92	38	147	97	173	121	206	152	240	188	316	262	102	154
	11	-	-	-	-	138	81	163	105	196	135	230	173	306	245	112	170
12	-	-	-	-	128	67	154	90	186	120	221	158	296	230	121	185	
VT-DFS075	5.0	183	130	325	266	402	346	457	399	526	467	602	545	728	668	102	159
	6.0	167	102	307	233	385	316	439	368	508	435	584	514	710	636	119	190
	7.0	149	73	287	201	366	286	420	337	488	403	565	484	689	604	139	221
	8.0	-	-	266	169	346	256	399	306	467	371	545	453	668	572	159	252
	9.0	-	-	246	137	328	226	381	275	448	339	527	423	649	540	178	283
	10.0	-	-	226	105	309	197	361	244	428	307	507	392	629	508	197	314
	11.0	-	-	-	-	237	167	342	213	407	275	488	362	609	476	217	345
12.0	-	-	-	-	272	137	322	182	387	243	469	331	589	444	236	376	
DFS085	5.0	278	187	469	366	591	496	703	604	798	696	917	820	1155	1053	166	266
	6.0	248	140	435	313	560	446	670	552	764	643	885	769	1122	100	199	317
	7.0	218	93	401	260	528	396	637	501	731	590	853	718	108	947	232	368
	8.0	-	-	368	207	497	347	605	449	698	536	821	668	1055	894	264	419
	9.0	-	-	335	154	467	297	574	398	665	483	790	617	1022	840	296	471
	10.0	-	-	301	101	435	248	541	346	631	430	758	567	988	787	328	522
	11.0	-	-	-	-	403	198	508	295	597	377	725	516	954	734	361	573
12.0	-	-	-	-	372	149	472	243	563	324	693	466	920	681	394	625	
VT-DFS100	5.0	418	305	722	595	871	752	1038	914	1189	1062	1385	1264	1729	1602	222	345
	6.0	377	241	676	523	827	684	993	844	1143	990	1341	1195	1683	1530	267	415
	7.0	335	177	629	450	784	617	947	774	1096	917	1297	1127	1636	1458	312	485
	8.0	-	-	582	378	740	549	902	709	1049	845	1252	1252	1589	1385	358	555
	9.0	-	-	536	306	696	482	857	634	1002	773	1208	1208	1543	1313	403	625
	10.0	-	-	490	234	654	415	812	565	957	701	1164	1164	1497	1241	447	694
	11.0	-	-	-	-	610	348	767	494	910	629	1120	1120	1450	1169	492	764
12.0	-	-	-	-	566	280	721	424	862	557	1074	1074	1403	1097	538	834	
VT-DFS115	5	716	513	1199	970	1487	1273	1731	1509	1987	1758	2267	2049	2774	2554	363	584
	6	651	407	1126	851	1418	1162	1660	1403	1913	1648	2197	1936	2701	2435	434	699
	7	586	301	1053	732	1350	1051	1589	1287	1831	1520	2127	1822	2628	2307	504	814
	8	-	-	970	613	1273	940	1518	1172	1758	1401	2049	1709	2554	2188	584	929
	9	-	-	897	494	1205	829	1447	1048	1685	1282	1979	1596	2472	2069	655	1044
	10	-	-	-	-	1136	718	1367	932	1611	1163	1910	1482	2399	1950	726	1159
	11	-	-	-	-	1068	607	1296	817	1538	1044	1840	1369	2325	1831	797	1274
12	-	-	-	-	-	-	1225	701	1456	925	1761	1256	2243	1712	867	1389	
VT-DFS125	5	911	667	1456	1181	1854	1598	2211	1944	2536	2261	2912	2651	3580	3305	451	717
	6	826	529	1360	1025	1765	1453	2117	1793	2440	2106	2821	2502	3484	3149	544	867
	7	741	399	1263	879	1675	1316	2024	1651	2344	1959	2729	2363	3387	3003	637	1009
	8	-	-	1163	723	1581	1171	1926	1500	2243	1804	2633	2215	3287	2847	735	1159
	9	-	-	1067	568	1491	1025	1833	1349	2147	1648	2542	2066	3191	2692	827	1310
	10	-	-	-	-	1401	880	1740	1198	2051	1492	2450	1918	3094	2536	920	1460
	11	-	-	-	-	1312	743	1647	1056	1955	1346	2359	1779	2998	2390	1013	1602
12	-	-	-	-	1218	598	1549	906	1854	1190	2263	1630	2898	2234	1111	1752	
VT-DFS145	5	1213	838	2142	1721	2897	2504	3382	2974	4120	3699	4438	4037	5576	5154	717	1124
	6	1074	627	1987	1483	2751	2281	3231	2743	3964	3461	4290	3810	5420	4916	867	1354
	7	936	415	1831	1245	2606	2059	3081	2512	3809	3223	4142	3584	5264	4678	1018	1584
	8	-	-	1685	1007	2469	1837	2939	2282	3662	2985	4002	3357	5118	4440	1159	1814
	9	-	-	1529	778	2324	16274	2788	2060	3506	2756	3854	3139	4962	4211	1310	2036
	10	-	-	1373	540	2179	1401	2637	1829	3351	2518	3706	2912	4806	3973	1460	2266
	11	-	-	-	-	2042	1179	2495	1598	3204	2280	3566	2686	4660	3735	1602	2496
12	-	-	-	-	1905	957	2353	1367	3058	2042	3427	2459	4514	3497	1743	2726	

VAHN-TECH International Inc. reserves the right to change the technical data without prior notice.

OUTPUT TORQUE OF SPRING RETURN ACTUATOR

Unit: in-lb

Model	Spring Qty.	40 PSI		60 PSI		70 PSI		80 PSI		90 PSI		100 PSI		120 PSI		Spring Return	
		0°	90°	0°	90°	0°	90°	0°	90°	0°	90°	0°	90°	0°	90°	0°	90°
VT-DFS160	5	1953	1506	3113	2609	3845	3375	4572	4084	5173	4669	5912	5432	7324	6821	974	1460
	6	1766	1237	2902	2307	3649	3093	4368	3791	4962	4367	5711	5144	7114	6518	1177	1752
	7	1579	960	2692	1996	3452	2803	4164	3489	4752	4056	5511	4848	6903	6207	1381	2053
	8	-	-	2481	1694	3256	2521	3959	3196	4541	3754	5310	4560	6692	5905	1584	2345
	9	-	-	2280	1382	3068	2230	3764	2894	4340	3442	5118	4264	6491	5594	1779	2646
	10	-	-	2069	1080	2871	1948	3560	2601	4129	3140	4918	3976	6280	5292	1982	2938
	11	-	-	-	-	2675	1658	3356	2299	3918	2829	4717	3680	6070	4980	2186	3239
12	-	-	-	-	2487	1376	3160	2006	3171	2527	4525	3392	5868	4678	2381	3531	
VT-DFS180	5	2352	1676	4129	3369	5161	4452	6143	5407	6903	6143	7917	7193	9897	9137	1381	2115
	6	2091	1294	3836	2939	4888	4050	5859	4989	6610	5713	7638	6784	9604	8707	1664	2531
	7	1831	911	3543	2509	4614	3649	5575	4572	6317	5283	7359	6374	9311	8276	1947	2947
	8	-	-	3250	2069	4341	3238	5291	4146	6024	4843	7080	5955	9018	7837	2230	3375
	9	-	-	2966	1639	4076	2837	5016	3729	5740	4413	6810	5545	8734	7407	2505	3788
	10	-	-	2673	1208	3802	2435	4732	3311	5447	3983	6531	5136	8441	6976	2788	4204
	11	-	-	-	-	3538	2034	4457	2894	5164	3552	6260	4726	8157	6546	3062	4620
12	-	-	-	-	3264	1632	4173	2477	4871	3122	5981	4316	7864	6116	3345	5036	
VT-DFS200	5	3328	2498	5713	4779	7195	6323	8425	7519	9558	8624	10864	9975	13412	12479	1912	2814
	6	2987	1986	5328	4202	6836	5785	8052	6960	9173	8047	10498	9425	13028	11902	2283	3372
	7	2645	1473	4944	3625	6477	5247	7679	6401	8789	7471	10132	8876	12643	11325	2655	3929
	8	-	-	4559	3058	6118	4717	7306	5850	8404	6903	9766	8336	12259	10757	3027	4478
	9	-	-	4166	2490	5751	4187	6925	5300	8011	6335	9391	7795	11865	10190	3407	5027
	10	-	-	3772	1913	5383	3649	6543	4741	7617	5759	9016	7246	11471	9613	3788	5584
	11	-	-	-	-	5024	3119	6170	4190	7233	5191	8649	6705	11087	9045	4160	6133
12	-	-	-	-	4657	2581	5788	3631	6839	4614	8275	6156	10693	8469	4540	6691	
VT-DFS240	5	5737	4419	9796	8313	12134	10749	14249	12811	16342	14859	18685	17273	22888	21405	3230	4664
	6	5135	3564	9119	7352	11501	9852	13592	11878	15665	13898	18040	16357	22210	20444	3885	5593
	7	4541	2694	8450	6372	10878	8938	12944	10929	14996	12936	17395	15450	21524	19482	4531	6540
	8	-	-	7736	5402	10245	8032	12287	9987	14319	11975	16758	14535	20846	18521	5186	7478
	9	-	-	7123	4449	9639	7143	11656	9064	13669	11014	16113	13628	20160	17560	5814	8399
	10	-	-	6445	3506	9006	6263	11000	8150	12991	10052	15459	12713	19491	16589	6469	9310
	11	-	-	-	-	8374	5358	10343	7209	12314	9100	14823	11788	18814	15637	7124	10248
12	-	-	-	-	7742	4426	9686	6241	11636	8148	14169	10882	18127	14667	7779	11213	
VT-DFS265	5	9790	7690	16278	13916	20149	17944	23597	21307	27081	24719	30849	28599	37793	35431	4797	7080
	6	8887	6429	15298	12479	19217	16577	22629	19886	26083	23254	29898	27204	36795	33966	5779	8452
	7	8016	5119	14319	11041	18286	15210	21742	18466	22613	21789	28948	25809	35797	32501	6726	9877
	8	-	-	13339	9567	17355	13843	20685	17045	24087	20324	27997	24414	34799	31036	7655	11284
	9	-	-	12359	8111	16423	12475	19726	15625	23089	18860	27047	23019	33709	29571	8673	12744
	10	-	-	11297	6628	15492	11108	18759	14204	22091	17395	26097	21624	32803	28106	9611	14125
	11	-	-	-	-	14560	9741	17791	12784	21094	15930	25146	20229	31805	26642	10558	15523
12	-	-	-	-	13672	8459	16823	11364	20096	14465	24196	18833	30807	25177	11505	16904	
VT-DFS300	5	11857	8854	20041	16662	25147	21994	29181	25905	33444	30066	38225	35008	46838	43460	6531	9797
	6	10661	7064	18695	14648	23891	20115	27876	23952	32098	28051	36943	46838	45492	41445	7832	11744
	7	9464	5265	17349	12625	22635	18226	26571	21990	30752	26028	35662	45492	44146	39422	9133	13700
	8	-	-	16003	10602	21379	16338	25266	20028	29406	24005	34380	44146	42800	37399	10434	15656
	9	-	-	14648	8578	20115	14449	23952	18066	28051	21982	33089	42800	41445	35376	11744	17612
	10	-	-	13302	6555	18858	12561	22647	16104	26706	19958	31808	41445	40100	33352	13045	19567
	11	-	-	-	-	17602	10672	21342	14142	25360	17935	30526	40100	38754	31329	14346	21523
12	-	-	-	-	-	-	20071	12247	24525	16701	28993	38754	37912	30088	15657	23481	
VT-DFS350	5	17326	12947	29278	24353	36683	32086	42613	37837	48843	43917	55829	51138	68398	63473	9523	14284
	6	15576	10327	27310	21405	34846	29334	40704	34978	46874	40969	53954	48331	66430	60525	11425	17134
	7	13834	7707	25351	18457	33017	26583	38805	32120	44915	38021	52089	45523	64471	57577	13319	19983
	8	-	-	23382	15509	31180	23832	36896	29261	42947	35073	50214	42715	62502	54629	1522	22833
	9	-	-	21414	12561	29343	21080	34987	26402	40979	32126	48339	39908	60534	51681	17125	25683
	10	-	-	19446	9613	27506	18329	33078	23544	39010	29178	46465	37100	58566	48733	19028	28532
	11	-	-	-	-	25677	15577	31179	20685	37051	26230	44599	34293	56606	45785	20921	31382
12	-	-	-	-	-	-	29333	17915	35840	24422	42370	30952	55387	43969	22826	34244	
VT-DFS400	5	27189	20337	45913	38205	57524	50329	66823	59348	76583	68874	87532	80191	107244	99535	14895	22346
	6	24446	16227	42828	33581	54644	46014	63831	54864	73498	64251	84594	75787	104158	94912	17877	26816
	7	21712	12117	39752	28958	51773	41699	60848	50381	70422	59628	81664	71384	101082	90288	20851	31285
	8	-	-	36666	24334	48894	37384	57856	45898	67336	55004	78726	66981	97997	85665	23833	35754
	9	-	-	33590	19711	46022	33068	54873	41415	64260	50381	75796	62578	94921	81042	26807	40223
	10	-	-	30505	15088	43143	28753	51882	36931	61175	45758	72858	58175	91836	76418	29789	44693
	11	-	-	-	-	40263	24438	48890	32448	58090	41134	69919	53771	88750	71795	32772	49162
12	-	-	-	-	-	-	45907	27965	55013	36511	66990	49368	85674	67172	35745	53631	

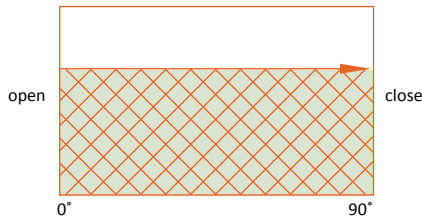

Output Torque of Double Acting Actuator

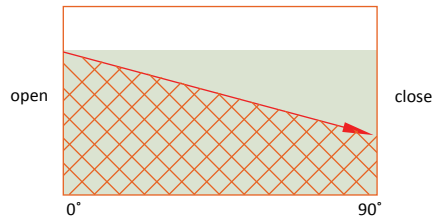

Output Torque of Spring Return Actuator

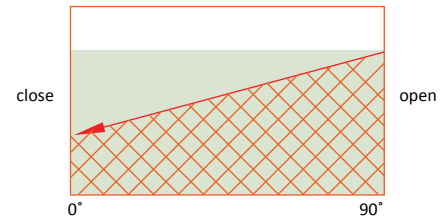

SERVICE CONDITIONS TO CONSIDER

1 Operating Media:

Dry or lubricated air, or inert gas, or non-corrosive gases compatible with actuator inner parts and lubricant are available. The media temperature must 10°C lower than ambient temperature at least, and the maximum particle diameter must be less than 20 μ.

2 Air Supply Pressure:

3 Bar (40 PSI) ~ 8 Bar (120 PSI)

3 Operating Temperature:

- a. Standard: -20°C ~ + 80°C
- b. Low Temperature: -40°C ~ + 80°C
- c. High Temperature: -15°C ~ + 150°C

4 Travel Adjustment

Range of ±5° for 90° rotation.

5 Lubricant:

Use a lubricant that the temperature range at -20°C to +80°C. Select special lubricant when the operating conditions are low temperature or high temperature.

Parts	The Grade of Anti-Corrosion	
	A	B
Body	Anodise Hardening + Epoxy Polyester Coating	Stainless Steel CF8 / CF8M
Cap	Anodise Hardening + Epoxy Polyester Coating	Stainless Steel CF8 / CF8M
Drive Shaft	Carbon Steel Nickel Plated	Stainless Steel CF8 / CF8M
Piston	Anodise Hardening	Stainless Steel CF8 / CF8M
Service Condition	Normal Condition of Low Thickness Acid Environment	High Thickness Acid Environment

ACTUATOR SIZING GUIDE

This reference data helps to choose appropriate DFS actuator. Before installing the actuator, one must consider the following factors:

- ✦ The operating life of this actuator is 3 years or 1 million times.
- ✦ Non-metal parts should be replaced when the actuator is used over half a million times. The operating air pressure for the actuator.
- ✦ The operation torque of the valve coupled with safety factor recommended.
- ✦ The types of actuator, i.e. Double Acting actuator and Spring Return Actuator, and its output torque under supply air pressure.
- ✦ Actuator's direction of rotation and failure mode (failure to open and close).
- ✦ It is very important to choose a correct actuator. For example, the stem will be overly loaded if the actuator is too big. Whereas, there will be insufficient torque to operate valve if the actuator is too small.

Torque Characteristics of Three Different Types of 90° Travel Valves

Ball Valve

Ball valve construction concept is based essentially on a polished ball (include a through port) contained in two seats (upstream and downstream). The ball rotation allows the flow, or stops the flow through the valve. Differential Pressure between upstream and downstream pressures forces the ball against the downstream seat (floating ball). In case, the valve torque is generated by the friction between ball and seat and also between stem and packing. As shown in the diagram, the highest torque point is when, in presence of pressure, the valve is in the closed position, and passes to the open position (breakaway torque).

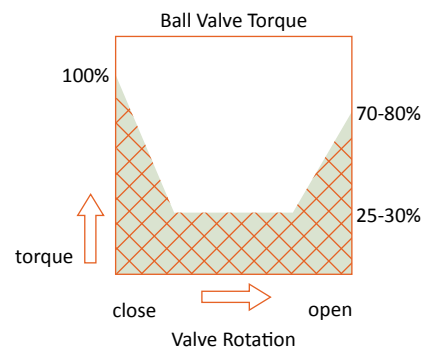

Butterfly Valve

Butterfly valve construction concept is based essentially on a disc fixed on an axis, which is the closed position, is completely contained by the seat. The open position is obtained when, with a rotation, the disc (through its stem) becomes parallel to the flow. On the contrary, the closed position is obtained when the disc is perpendicular to the flow. In the case of the butterfly valve, the torque is generated by the friction between the disc and the seat, by the stem packing and also by the differential pressure that forces on the disc. The highest torque point, as shown in the diagram, is in the closed position, and only after a small rotation it is considerably reduced.

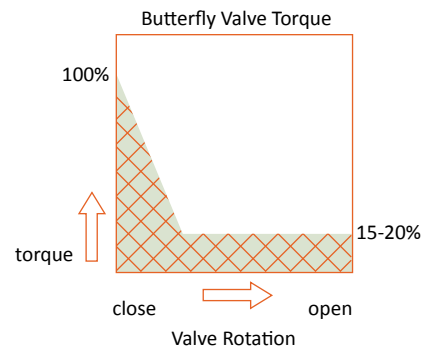

Plug Valve

The construction principle of the plug is basically according to the plug sealed in the conical cock body. There is a channel at a direction of the plug. Along with the plug screws in the valve, the valve will open or close. The operating torque is decided by the friction of the valve seat and the plug during the open and close process and is often not influenced by the fluid's pressure. As shown in the picture. The torque is maximal when the valve closes. As without the influence of the pressure, the superior torque will be kept at the following operation.

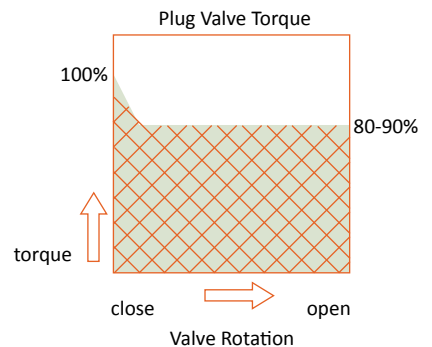

ACTUATOR SIZING GUIDE

Double Acting Actuation

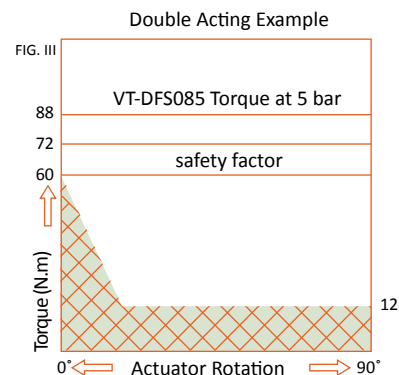
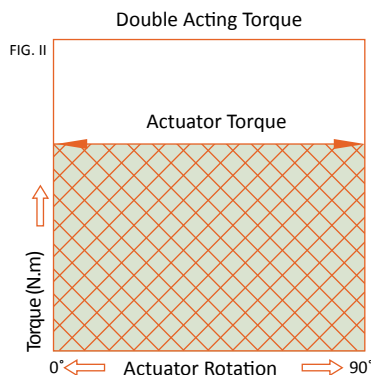
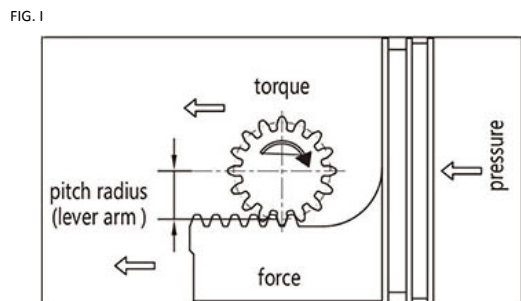

The output torque of the rack and pinion pneumatic actuator = piston pressure (air supply pressure) x pitch radius (lever of arm), as indicated in **FIG. I**. Besides, the friction resistance and efficiency are very high. As **FIG. II**, both of the output torque are linear when CCW or CW. The suggested safety factor for double acting actuators under normal working conditions is 15% -20%.

EXAMPLE:

(Check the Technical Data Sheet)

Butterfly valve's output torque	=	60 NM
Safety Factor (20%)	=	60 NM x (1+20%) = 72 NM
Air Supply Pressure	=	5 Bar

✦ Under 5 Bar operating pressure for a torque valve of 72 NM, most suitable actuator will be VT-DFS-085.

Spring Return Actuation Sizing Guide:

In the application of SR actuator, the output torque is coming from two different process of operation (Fig. 1 and Fig. 2). According to the travel position (0° and 90°), every operation gets two different torque, SR actuator's output torque = pressure (air or spring work on the piston) x pitch radius (lever arm).

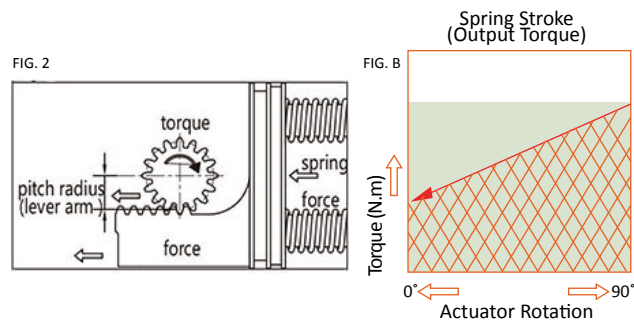
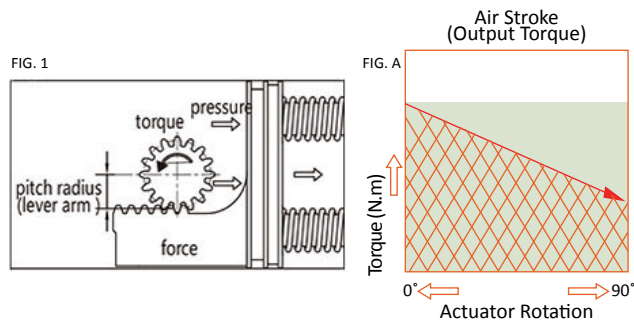

Output is coming from air supply pressure inside the Port 2 and squeezing the spring. It is known as "air travel output torque". In this situation, air supply pressure pressurized from 0° position to 90° position (FIG. A).

The output torque is coming from the spring return forcing work on the piston when out of air. It is known as "spring travel output torque". In this situation, because of the comeback of spring, torque is decreasing gradually from the starting 90° position to 0° position (FIG. B).

In a word, DFS actuator is designed based on the fact that two situations get one balanced torque, i.e. the numbers of springs are the same as air supply pressure readings each side (4 bar, 4 springs each side), as shown in Fig. C. There are possibilities to get an unbalanced torque in every situation, as shown in Fig. D, by changing the number of springs and air supply pressure (such as six springs each side and 5.5 Bar air supply, and vice versa.)

ACTUATOR SIZING GUIDE

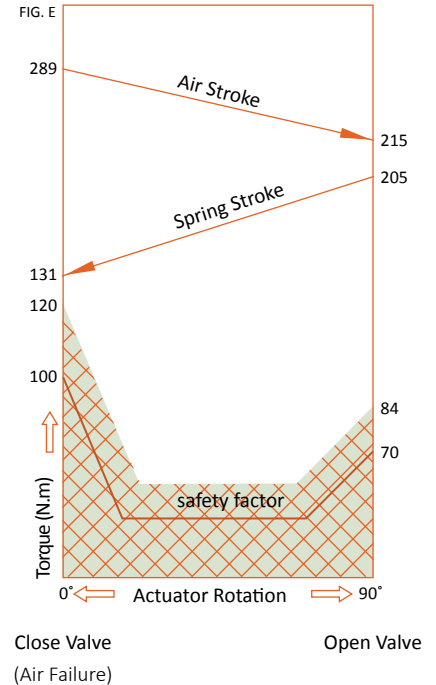
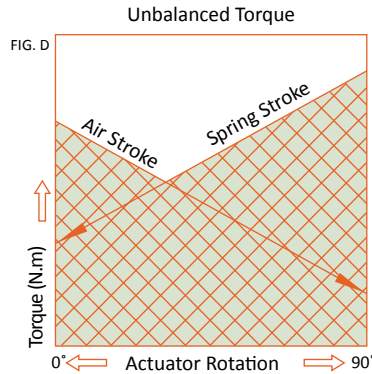
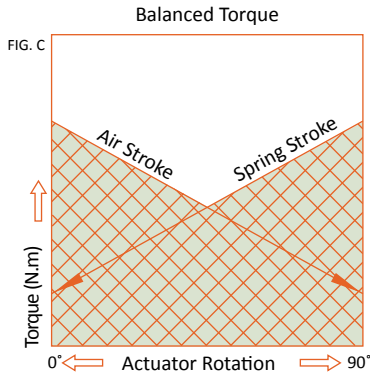

In the application of SR actuator, there are two situations: out of the air open or out of the air close. The suggested safety factor for spring return actuator under working conditions is 20% - 25%.

EXAMPLE:

(Check the Technical Data Sheet)

Spring Closed (out of the air)	
Ball Valve's Output Torque	= 100 NM
Safety Factor)20%	= 100 x (1 + 20%) = 120 NM
Air Supply Pressure	= 5 Bar

The selected actuator is DFS145, therefore it gets the following data (Fig. E);

Spring Stroke 0°	= 131 NM
Spring Stroke 90°	= 205 NM
Air Stroke 0°	= 289 NM
Air Stroke 90°	= 215 NM

TROUBLE SHOOTING

Trouble Phenomena	Checking Item	Solutions
Trouble Phenomena	1. Does the solenoid work normally?	1. Replace the solenoid.
	2. Is the circuit burned?	2. Replace the circuit.
	3. Is the mandrel of the solenoid blocked by impurity?	3. Replace the impurity.
	With air supplying the Pneumatic actuator, are the o-rings or the cylinder broken?	Replaced the broken o-rings and cylinder body.
	Is impurity blocking the valve?	Clean out the impurity, replaced the broken parts.
	Is the handle of the manual equipment at the manual state?	Put the handle to the Pneumatic state.
Acting Slowly	Is the air supply pressure insufficient?	Improve the air pressure.
	Is the output torque of the pneumatic actuator not enough?	Select a bigger model of the Pneumatic actuator.
	Is the valve stem of other parts assembled to tightened?	Reassemble and adjust the valve.
	Is the air supply pipe blocked making the air flux to small?	Clean out the block replaced the filter stem.
The Feedback has no Signal	Is the power shorted put or stopped?	Check the circuitry.
	Is the cam of the feedback in the incorrect position?	Adjust the cam to the correct position.
	Is the jiggle on-off broken?	Replaced the jiggle on-off.

ACCESSORIES

Inserts

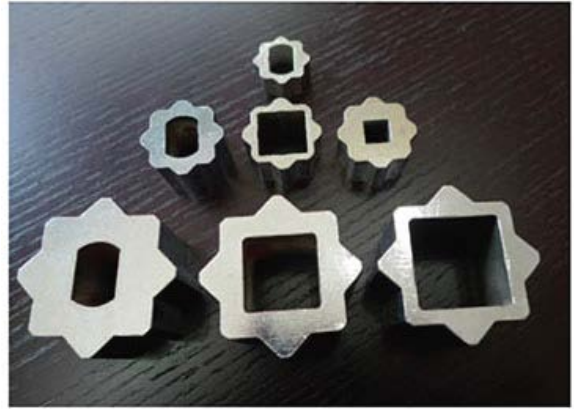
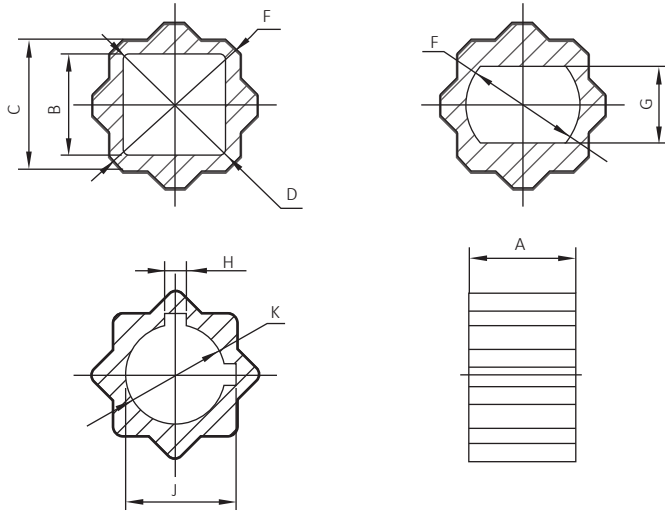

Model	A		B		C		D		E		F		G		H		J		K			
	mm	in	mm	in	mm	in	mm	in	mm	in	mm	in	mm	in	mm	in	mm	in	mm	in		
VT-DFS050	1	12.0	0.47	14.0	0.55	17.0	0.67	Ø19.2	Ø0.76	Ø22.2	Ø0.87	-	-	-	-	-	-	-	-	-	-	
	2	12.0	0.47	11.0	0.43	17.0	0.67	Ø15.2	Ø0.60	Ø22.2	Ø0.87	-	-	-	-	-	-	-	-	-	-	
	3	12.0	0.47	9.0	0.35	17.0	0.67	Ø12.5	Ø0.49	Ø22.2	Ø0.87	-	-	-	-	-	-	-	-	-	-	
	4	12.0	0.47	-	-	17.0	0.67	-	-	Ø22.2	Ø0.87	Ø14.4	Ø0.57	9.6	0.38	-	-	-	-	-	-	-
	5	12.0	0.47	-	-	17.0	0.67	-	-	Ø22.2	Ø0.87	-	-	-	-	3.1	0.12	-	-	Ø12.8	Ø0.50	
VT-DFS063	1	16.0	0.63	14.0	0.55	17.0	0.67	Ø19.2	Ø0.76	Ø22.2	Ø0.87	-	-	-	-	-	-	-	-	-	-	
	2	16.0	0.63	11.0	0.43	17.0	0.67	Ø15.2	Ø0.60	Ø22.2	Ø0.87	-	-	-	-	-	-	-	-	-	-	
	3	16.0	0.63	9.0	0.35	17.0	0.67	Ø12.5	Ø0.49	Ø22.2	Ø0.87	-	-	-	-	-	-	-	-	-	-	
	4	16.0	0.63	-	-	17.0	0.67	-	-	Ø22.2	Ø0.87	Ø14.4	Ø0.57	9.6	0.38	-	-	-	-	-	-	-
	5	16.0	0.63	-	-	17.0	0.67	-	-	Ø22.2	Ø0.87	-	-	-	-	3.1	0.12	-	-	Ø12.8	Ø0.50	
VT-DFS075 VT-DFS085	1	18.0	0.71	19.0	0.75	22.0	0.87	Ø26.2	Ø1.03	Ø28.2	Ø1.11	-	-	-	-	-	-	-	-	-	-	
	2	18.0	0.71	17.0	0.67	22.0	0.87	Ø23.2	Ø0.91	Ø28.2	Ø1.11	-	-	-	-	-	-	-	-	-	-	
	3	18.0	0.71	14.0	0.55	22.0	0.87	Ø19.2	Ø0.76	Ø28.2	Ø1.11	-	-	-	-	-	-	-	-	-	-	
	4	18.0	0.71	11.0	0.43	22.0	0.87	Ø15.2	Ø0.60	Ø28.2	Ø1.11	Ø14.4	Ø0.57	9.6	0.38	-	-	-	-	-	-	-
	5	18.0	0.71	9.0	0.35	22.0	0.87	Ø12.5	Ø0.49	Ø28.2	Ø1.11	Ø16.0	Ø0.63	11.2	0.44	-	-	-	-	-	-	-
	6	18.0	0.71	-	-	22.0	0.87	-	-	Ø28.2	Ø1.11	Ø19.2	Ø0.76	12.8	0.55	-	-	-	-	-	-	-
	7	18.0	0.71	-	-	22.0	0.87	-	-	Ø28.2	Ø1.11	-	-	-	-	5.1	0.20	-	-	Ø15.9	Ø0.63	
VT-DFS100 VT-DFS115	1	23.0	0.91	19.0	0.75	22.0	0.87	Ø26.2	Ø1.02	Ø28.2	Ø1.11	-	-	-	-	-	-	-	-	-	-	
	2	23.0	0.91	17.0	0.67	22.0	0.87	Ø23.2	Ø0.91	Ø28.2	Ø1.11	-	-	-	-	-	-	-	-	-	-	
	3	23.0	0.91	14.0	0.55	22.0	0.87	Ø19.2	Ø0.76	Ø28.2	Ø1.11	-	-	-	-	-	-	-	-	-	-	
	4	23.0	0.91	11.0	0.43	22.0	0.87	Ø15.2	Ø0.60	Ø28.2	Ø1.11	Ø14.4	Ø0.57	9.6	0.38	-	-	-	-	-	-	-
	5	23.0	0.91	-	-	22.0	0.87	-	-	Ø28.2	Ø1.11	Ø16.0	Ø0.63	11.2	0.44	-	-	-	-	-	-	-
	6	23.0	0.91	-	-	22.0	0.87	-	-	Ø28.2	Ø1.11	Ø19.2	Ø0.76	12.8	0.55	-	-	-	-	-	-	-
	7	23.0	0.91	-	-	22.0	0.87	-	-	Ø28.2	Ø1.11	-	-	-	-	5.1	0.20	-	-	Ø19.2	Ø0.75	
VT-DFS125 VT-DFS145 VT-DFS160	1	29.0	1.14	27.0	1.06	36.0	1.42	Ø37.2	Ø1.46	Ø48.2	Ø1.9	-	-	-	-	-	-	-	-	-	-	
	2	29.0	1.14	22.0	0.87	36.0	1.42	Ø29.2	Ø1.15	Ø48.2	Ø1.9	-	-	-	-	-	-	-	-	-	-	
	3	29.0	1.14	19.0	0.75	36.0	1.42	Ø26.2	Ø1.03	Ø48.2	Ø1.9	-	-	-	-	-	-	-	-	-	-	
	4	29.0	1.14	-	-	36.0	1.42	-	-	Ø48.2	Ø1.9	Ø22.4	Ø0.88	16.0	0.63	-	-	-	-	-	-	-
	5	29.0	1.14	-	-	36.0	1.42	-	-	Ø48.2	Ø1.9	Ø19.2	Ø0.76	12.8	0.50	-	-	-	-	-	-	-
	6	29.0	1.14	-	-	36.0	1.42	-	-	Ø48.2	Ø1.9	Ø18.0	Ø0.63	11.2	0.44	-	-	-	-	-	-	-
	7	29.0	1.14	-	-	36.0	1.42	-	-	Ø48.2	Ø1.9	-	-	-	-	6.4	0.25	31.8	1.25	Ø28.7	Ø1.13	
	8	29.0	1.14	-	-	36.0	1.42	-	-	Ø48.2	Ø1.9	-	-	-	-	8.1	0.32	-	-	Ø28.7	Ø1.13	
VT-DFS180	1	42.0	1.65	27.0	1.06	36.0	1.42	Ø37.2	Ø1.46	Ø48.2	Ø1.9	-	-	-	-	-	-	-	-	-	-	
	2	42.0	1.65	22.0	0.87	36.0	1.42	Ø29.2	Ø1.15	Ø48.2	Ø1.9	-	-	-	-	-	-	-	-	-	-	
	3	42.0	1.65	-	-	36.0	1.42	-	-	Ø48.2	Ø1.9	-	-	-	-	6.4	0.25	31.8	1.25	Ø28.7	Ø1.13	
	4	42.0	1.65	-	-	36.0	1.42	-	-	Ø48.2	Ø1.9	Ø22.4	Ø0.88	16.0	0.63	-	-	-	-	-	-	-
	5	42.0	1.65	-	-	36.0	1.42	-	-	Ø48.2	Ø1.9	-	-	-	-	8.1	0.32	-	-	Ø31.9	Ø1.26	
VT-DFS200	1	42.0	1.65	27.0	1.06	36.0	1.42	Ø37.2	Ø1.46	Ø48.2	Ø1.9	-	-	-	-	-	-	-	-	-	-	
	2	42.0	1.65	-	-	36.0	1.42	-	-	Ø48.2	Ø1.9	-	-	-	-	6.4	0.25	31.8	1.25	Ø28.7	Ø1.13	
	3	42.0	1.65	-	-	36.0	1.42	-	-	Ø48.2	Ø1.9	-	-	-	-	10.1	0.40	-	-	Ø33.5	Ø1.32	

ACCESSORIES

Plates & Brackets

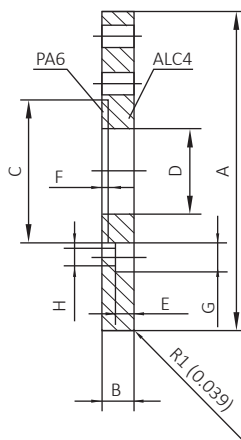
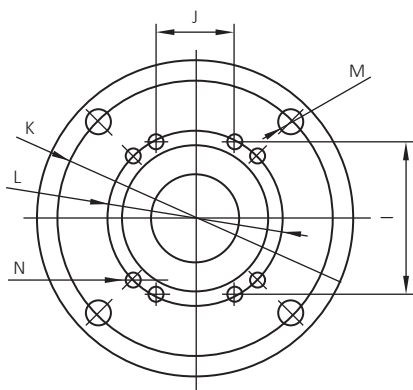

Model	VT-DFS050		VT-DFS063/075/085		VT-DFS100/115		VT-DFS125/145/160		VT-DFS180/200	
	mm	in	mm	in	mm	in	mm	in	mm	in
A	Ø102.0	Ø4.00	Ø102.0	Ø4.00	Ø102.0	Ø4.00	Ø152.4	Ø6.00	Ø152.4	Ø6.00
B	12.0	0.47	12.0	0.47	15.0	0.59	15.0	0.59	20.0	0.79
C	Ø28.5	Ø1.11	Ø38.5	Ø1.51	Ø38.5	Ø1.51	Ø63.0	Ø2.64	Ø81.0	Ø3.19
D	Ø17	Ø0.67	Ø21.0	Ø0.83	Ø21.0	Ø0.83	Ø40.0	Ø1.57	Ø40.0	Ø1.57
E	6.0	0.24	7.0	0.28	9.0	0.35	9.0	0.35	11.0	0.43
F	3.0	0.12	3.0	12.00	3.0	0.12	3.0	0.12	3.0	0.12
G	Ø9.5	Ø0.37	Ø11.0	Ø0.43	Ø14.0	Ø0.55	Ø14.0	Ø0.55	Ø17.0	Ø0.67
H	Ø5.2	Ø0.20	Ø6.2	Ø0.24	Ø8.2	Ø0.33	Ø8.2	Ø0.33	Ø10.5	Ø0.41
I	-	-	-	-	72.0	2.83	72.0	2.83	99.0	3.90
J	-	-	-	-	37.0	1.46	37.0	1.46	53.0	2.08
K	Ø82.6	Ø3.25	Ø82.6	Ø3.25	Ø82.6	Ø3.25	Ø127.0	Ø5.00	Ø127.0	Ø5.00
L	-	-	-	-	-	-	Ø82.6	Ø3.25	-	-
M	M10	3/8-16UNC	M10	3/8-16UNC	M10	3/8-16UNC	M12	1/2-13UNC	M12	1/2-13UNC
N	-	-	-	-	-	-	M10	3/8-16UNC	-	-

We design and produce a series of connection flange and adapter kit to install actuator on valve conveniently, or use ISO bracket or ISO gear box connection transition.

Connection Bracket, CF8 (304) castings, converted size:

- F03 / F04 to F03 / F05 H = 29.5mm;
- F04 / F05 to F04 / F05 H = 29.5mm;
- F04 / F05 to F05 / F07 H = 29.5mm;
- F05 / F07 to F07 / F10 H = 40.0mm;
- F07 / F10 to F07 / F10 H = 44.0mm;

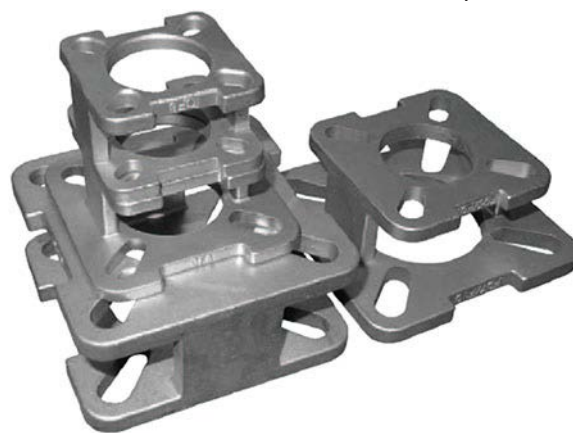

How to Order

Example: VT - DFS400 - SR - 05 - 90° - M - P

Model	Double Acting	Spring Return	Spring Code	Open Angle	Thread	Options
DFS032	DA	SR	02	0° ~ 90°	I = Imperial Unit	P = Normal Temp. NBR Seal (-40°F ~ 126°F / -40°C ~ 80°C)
DFS040			04		(in-Lb)	
DFS063			05		M = Metric Unit	P1 = High Temp. Viton Seal (-40°F ~ 250°F / -40°C ~ 120°C)
DFS075			06		(N.m)	
DFS085			07			P2 = Low Temp. Silicon Seal (-40°F ~ 176°F / -40°C ~ 80°C)
DFS100			08			T = Actuator Locking Device
DFS115			09			L = A Port Airing, Clockwise Rotation
DFS125			10			
DFS145			11			
DFS160			12			
DFS180						
DFS200						
DFS240						
DFS265						
DFS300						
DFS350						
DFS400						





VAHN-TECH International Inc.

10-755 Queensway East, Mississauga, Ontario L4Y 4C5, Canada
Tel.: +1 416 342 0001 E-mail: info@vahn-tech.com

www.vahn-tech.com